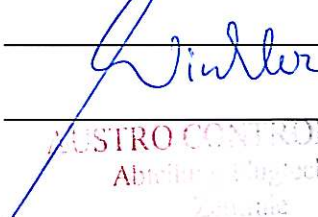

AIRPLANE FLIGHT MANUAL
DA 40

N232DS

Airworthiness Category : Normal, Utility
Requirement : JAR-23
Serial Number : _____
Registration : _____
Doc. No. : 6.01.01-E
Date of Issue : 26 June 2000

Signature :  _____
Authority : _____
Stamp : 
AUSTRO CONTROL GmbH
Abteilung Flugtechnik
Zentrale
A-1030 Wien, Schmirchgasse 11
Date of approval : 09. DEZ. 2004

- | This Flight Manual has been verified for EASA by the Austrian Civil Aviation Authority
- | Austro Control (ACG) as Primary Certification Authority (PCA) in accordance with the
- | valid Certification Procedures and approved by EASA with approval no. 2004-12326
- | This Flight Manual has been approved by EASA on behalf of CAAC-AAD.

DIAMOND AIRCRAFT INDUSTRIES GMBH
N.A. OTTO-STR. 5
A-2700 WIENER NEUSTADT
AUSTRIA

FOREWORD

We congratulate you on the acquisition of your new DIAMOND STAR.

Skillful operation of an airplane increases both safety and the enjoyment of flying. Please take the time therefore, to familiarize yourself with your new DIAMOND STAR.

This airplane may only be operated in accordance with the procedures and operating limitations of this Airplane Flight Manual.

Before this airplane is operated for the first time, the pilot must familiarize himself with the complete contents of this Airplane Flight Manual.

In the event that you have obtained your DIAMOND STAR second-hand, please let us know your address, so that we can supply you with the publications necessary for the safe operation of your airplane.

This document is protected by copyright. All associated rights, in particular those of translation, reprinting, radio transmission, reproduction by photo-mechanical or similar means and storing in data processing facilities, in whole or part, are reserved.

Copyright © by: DIAMOND AIRCRAFT INDUSTRIES GMBH
N.A. Otto-Strasse 5
A-2700 Wiener Neustadt, Austria
Phone. : +43-2622-26700
Fax : +43-2622-26780
E-Mail : office@diamond-air.at

0.1 APPROVAL

The content of approved chapters is approved by EASA. All other content is approved by DAI under the authority of EASA DOA No. EASA.21J.052 in accordance with Part 21.

0.2 RECORD OF REVISIONS

All revisions of this manual, with the exception of -

- Temporary Revisions,
- updates of the modification level (Section 1.1),
- updated mass and balance information (Section 6.3),
- updates of the Equipment Inventory (Section 6.5), and
- updates of the List of Supplements (Section 9.2)

must be recorded in the following table.

The new or amended text is indicated by a vertical black line at the left hand side of the revised page, with the revision number and date appearing at the bottom of the page.

NOTE

If pages are revised which contain information valid for your particular serial number (modification level of the airplane, weighing data, Equipment Inventory, List of Supplements), then this information must be transferred to the new pages in hand-writing.

Temporary Revisions, if applicable, are inserted into this manual. Temporary Revisions are used to provide information on systems or equipment until the next 'permanent' Revision of the Airplane Flight Manual. When a 'permanent' Revision covers a Mandatory or Optional Design Change Advisory (MÄM or OÄM), then the corresponding Temporary Revision is superseded. For example: Revision 5 covers OÄM-40-061, therefore the Temporary Revision TR-OÄM-40-061 is superseded by the 'permanent' Revision 5.

Rev. No.	Reason	Chapter	Page(s)	Date of Revision	Approval	Date of Approval	Date Inserted	Signature
1	corrections	all	all	26-Sep-2000	[approved by Ing. Andreas Winkler for ACG]	09-Oct-2000		
2	OÄM 40-060 (White Wire optional)	0	0-2, 0-4 thru 0-7	19-Dec-2000	approved by Ing. Andreas Winkler for ACG]	25-Jan-2001		
		1	1-16					
		2	2-1, 2-7 thru 2-9, 2-13 thru 2-19					
	OÄM 40-068 (Essential Bus)	3	3-7, 3-8, 3-19, 3-20, 3-25, 3-26					
		4A	4A-3 thru 4A-8, 4A-14, 4A-15					
	OÄM 40-073 (LASAR optional)	4B	4B-4 thru 4B-6					
		6	6-1, 6-2, 6-12 thru 6-14					
	corrections	7	7-1, 7-8, 7-14, 7-28 thru 7-38					
3	OÄM 40-064 (Night VFR)	0	0-2 thru 0-7	05-Feb-2001	[approved by Ing. Andreas Winkler for ACG]	02 Jul 2001		
		1	1-2					
		2	2-1, 2-8, 2-9, 2-12, 2-15 thru 2-20					
	OÄM 40-069 (control surf. gust lock)	3	3-1, 3-25 thru 3-27					
		4A	4A-1, 4A-8 thru 4A-31					
	OÄM 40-070 (tow bar)	5	5-7, 5-14, 5-16					
		6	6-7, 6-9, 6-12 thru 6-14					
	corrections	7	7-32, 7-35, 7-36					
8	8-1 thru 8-9							

Rev. No.	Reason	Chapter	Page(s)	Date of Revision	Approval	Date of Approval	Date Inserted	Signature
4	OÄM 40-067 (IFR) corrections	all	all	09 Apr 2001	[approved by Ing. Andreas Winkler for ACG]	02 Jul 2001		
5	OÄM 40-061 (KAP 140 autopilot)	0	0-1 thru 0-8	09 Sep 2001	[approved by Ing. Andreas Winkler for ACG]	09 Sep 2001		
	OÄM 40-073 (SlickSTART)	1	1-2, 1-5, 1-14					
	OÄM 40-081 (door lock)	2	2-1, 2-16, 2-22, 2-23, 2-24					
	OÄM 40-085 (KX 155A as COM 1)	3	3-13, 3-18, 3-22, 3-23, 3-24, 3-31, 3-36					
	OÄM's 40-092 thru 40-094 (Mikrotechna ASI, altimeter, VSI)	4A	4A-8, 4A-10, 4A-22, 4A-23, 4A-26					
	MÄM 40-039/a (VM 1000)	4B	4B-1, 4B-8					
	MÄM 40-048 (RH emerg. window)	6	6-5, 6-8 thru 6-17					
		7	7-13, 7-14, 7-33, 7-35					
		8	8-10					
	9	9-3, 9-4, 9-5						

Rev. No.	Reason	Chapter	Page(s)	Date of Revision	EASA Approval No.	ACG Compliance	Date Inserted	Signature
6	type certification in China	0	0-0, 0-5, 0-6	15 Sep 2004	2004-12326	[Ing. Andreas Winkler for ACG]		
7	<p>MÄM-40- -047, -069, -075, -078, -096, -099, -123e, -133, -141, -174, -175;</p> <p>OÄM-40- -063/b, -071/c, -077, -078, -080, -083/a, -090, -091, -097, -098, -103, -104, -105, -106, -111, -112, -114, -115, -117, -117/a, -119, -120, -121, -122, -124, -127, -128, -138, -140, -154, -165, -167, -168, -179, -181, -183, -185, -186, -190, -198, -200, -206, -237, 250/a;</p> <p>RÄM-40- -014;</p> <p>corrections; double-sided layout</p>	all	all except cover page	15 Jul 2006	Revision No. 7 of the AFM Doc. No. 6.01.01-E is approved under the authority of DOA No. EASA.21J.052	[11 Aug 2006 Dipl.-Ing. (FH) Manfred Reichel for DAI]		

Rev. No.	Reason	Chapter	Page(s)	Date of Revision	EASA Approval No.	ACG Compliance	Date Inserted	Signature
8	<p>MÄM-40- -176, -227/a, -313, -344, -360/a, -378, -401, -415, -428, -446;</p> <p>OÄM-40- -217, -251, -253/b, 258, -267, -277/a, -279, 283/a, -284, -289, -326, -327;</p> <p>corrections</p>	all	all except cover page	01 Dec 2010	Revision No. 8 of the AFM Doc. No. 6.01.01-E is approved under the authority of DOA No. EASA.21J.052			
9	<p>MÄM 40- -580, -617,</p> <p>OÄM 40- -252, -362, -369, -371</p>	0, 1, 2, 3, 4A, 6, 7	0-5, 0-6, 0-7, 0-8, 0-9, 0-11, 0-12, 0-13, 1-3, 1-7, 2-22, 2-25, 3-29, 4A-11, 4A-12, 4A-22 thru 4A-24, 4A-34, 4A-35, 6-17 thru 6-34, 7-1, 7.2, 7-15 thru 7-58	31 Jan 2014	Revision No. 9 of the AFM Doc. No. 6.01.01-E is approved under the authority of DOA No. EASA.21J.052			

0.3 LIST OF EFFECTIVE PAGES

Ch.	Page	Date
0	0-0	15-Sep-2004
	0-0a	15-Sep-2004
	0-1	01-Dec-2010
	0-2	01-Dec-2010
	0-3	01-Dec-2010
	0-4	01-Dec-2010
	0-5	31-Jan-2014
	0-6	31-Jan-2014
	0-7	31-Jan-2014
	0-8	31-Jan-2014
	0-9	31-Jan-2014
	0-10	01-Dec-2010
	0-11	31-Jan-2014
	0-12	31-Jan-2014
0-13	31-Jan-2014	
0-14	01-Dec-2010	

Ch.	Page	Date
1	1-1	01-Dec-2010
	1-2	01-Dec-2010
	1-3	31-Jan-2014
	1-4	01-Dec-2010
	1-5	01-Dec-2010
	1-6	01-Dec-2010
	1-7	31-Jan-2014
	1-8	01-Dec-2010
	1-9	01-Dec-2010
	1-10	01-Dec-2010
	1-11	01-Dec-2010
	1-12	01-Dec-2010
	1-13	01-Dec-2010
	1-14	01-Dec-2010
	1-15	01-Dec-2010
	1-16	01-Dec-2010
	1-17	01-Dec-2010
	1-18	01-Dec-2010
	1-19	01-Dec-2010
	1-20	01-Dec-2010
	1-21	01-Dec-2010
	1-22	01-Dec-2010
	1-23	01-Dec-2010
	1-24	01-Dec-2010

Ch.	Page	Date
2	appr. 2-1	01-Dec-2010
	appr. 2-2	01-Dec-2010
	appr. 2-3	01-Dec-2010
	appr. 2-4	01-Dec-2010
	appr. 2-5	01-Dec-2010
	appr. 2-6	01-Dec-2010
	appr. 2-7	01-Dec-2010
	appr. 2-8	01-Dec-2010
	appr. 2-9	01-Dec-2010
	appr. 2-10	01-Dec-2010
	appr. 2-11	01-Dec-2010
	appr. 2-12	01-Dec-2010
	appr. 2-13	01-Dec-2010
	appr. 2-14	01-Dec-2010
	appr. 2-15	01-Dec-2010
	appr. 2-16	01-Dec-2010
	appr. 2-17	01-Dec-2010
	appr. 2-18	01-Dec-2010
	appr. 2-19	01-Dec-2010
	appr. 2-20	01-Dec-2010
	appr. 2-21	01-Dec-2010
	appr. 2-22	31-Jan-2014
	appr. 2-23	01-Dec-2010
	appr. 2-24	01-Dec-2010
	appr. 2-25	31-Jan-2014
	appr. 2-26	01-Dec-2010
	appr. 2-27	01-Dec-2010

Ch.	Page	Date
2	appr. 2-28	01-Dec-2010
	appr. 2-29	01-Dec-2010
	appr. 2-30	01-Dec-2010
	appr. 2-31	01-Dec-2010
	appr. 2-32	01-Dec-2010
	appr. 2-33	01-Dec-2010
	appr. 2-34	01-Dec-2010

Ch.	Page	Date
3	3-1	01-Dec-2010
	3-2	01-Dec-2010
	3-3	01-Dec-2010
	3-4	01-Dec-2010
	3-5	01-Dec-2010
	3-6	01-Dec-2010
	3-7	01-Dec-2010
	3-8	01-Dec-2010
	3-9	01-Dec-2010
	3-10	01-Dec-2010
	3-11	01-Dec-2010
	3-12	01-Dec-2010
	3-13	01-Dec-2010
	3-14	01-Dec-2010
	3-15	01-Dec-2010
	3-16	01-Dec-2010
	3-17	01-Dec-2010
	3-18	01-Dec-2010
	3-19	01-Dec-2010
	3-20	01-Dec-2010
	3-21	01-Dec-2010
	3-22	01-Dec-2010
	3-23	01-Dec-2010
	3-24	01-Dec-2010
	3-25	01-Dec-2010
	3-26	01-Dec-2010
	3-27	01-Dec-2010
	3-28	01-Dec-2010

||

Ch.	Page	Date
3	3-29	31-Jan-2014
	3-30	31-Jan-2014
	3-31	01-Dec-2010
	3-32	01-Dec-2010
	3-33	01-Dec-2010
	3-34	01-Dec-2010
	3-35	01-Dec-2010
	3-36	01-Dec-2010
	3-37	01-Dec-2010
	3-38	01-Dec-2010
	3-39	01-Dec-2010
	3-40	01-Dec-2010
	3-41	01-Dec-2010
	3-42	01-Dec-2010

Ch.	Page	Date
4A	4A-1	01-Dec-2010
	4A-2	01-Dec-2010
	4A-3	01-Dec-2010
	4A-4	01-Dec-2010
	4A-5	01-Dec-2010
	4A-6	01-Dec-2010
	4A-7	01-Dec-2010
	4A-8	01-Dec-2010
	4A-9	01-Dec-2010
	4A-10	01-Dec-2010
	4A-11	31-Jan-2014
	4A-12	31-Jan-2014
	4A-13	01-Dec-2010
	4A-14	01-Dec-2010
	4A-15	01-Dec-2010
	4A-16	01-Dec-2010
	4A-17	01-Dec-2010
	4A-18	01-Dec-2010
	4A-19	01-Dec-2010
	4A-20	01-Dec-2010
	4A-21	01-Dec-2010
	4A-22	31-Jan-2014
	4A-23	31-Jan-2014
	4A-24	31-Jan-2014
	4A-25	01-Dec-2010
	4A-26	01-Dec-2010
	4A-27	01-Dec-2010

Ch.	Page	Date
4A	4A-28	01-Dec-2010
	4A-29	01-Dec-2010
	4A-30	01-Dec-2010
	4A-31	01-Dec-2010
	4A-32	01-Dec-2010
	4A-33	01-Dec-2010
	4A-34	31-Jan-2014
	4A-35	31-Jan-2014
	4A-36	01-Dec-2010
	4A-37	01-Dec-2010
	4A-38	01-Dec-2010
	4A-39	01-Dec-2010
	4A-40	01-Dec-2010

Ch.	Page	Date
4B	4B-1	01-Dec-2010
	4B-2	01-Dec-2010
	4B-3	01-Dec-2010
	4B-4	01-Dec-2010
	4B-5	01-Dec-2010
	4B-6	01-Dec-2010
	4B-7	01-Dec-2010
	4B-8	01-Dec-2010
	4B-9	01-Dec-2010
	4B-10	01-Dec-2010
	4B-11	01-Dec-2010
	4B-12	01-Dec-2010

Ch.	Page	Date
5	5-1	01-Dec-2010
	5-2	01-Dec-2010
	5-3	01-Dec-2010
	5-4	01-Dec-2010
	5-5	01-Dec-2010
	5-6	01-Dec-2010
	5-7	01-Dec-2010
	5-8	01-Dec-2010
	5-9	01-Dec-2010
	5-10	01-Dec-2010
	5-11	01-Dec-2010
	5-12	01-Dec-2010
	5-13	01-Dec-2010
	5-14	01-Dec-2010
	5-15	01-Dec-2010
	5-16	01-Dec-2010
	5-17	01-Dec-2010
	5-18	01-Dec-2010
	5-19	01-Dec-2010
	5-20	01-Dec-2010
	5-21	01-Dec-2010
	5-22	01-Dec-2010
	5-23	01-Dec-2010
	5-24	01-Dec-2010

Ch.	Page	Date
6	6-1	01-Dec-2010
	6-2	01-Dec-2010
	6-3	01-Dec-2010
	6-4	01-Dec-2010
	6-5	01-Dec-2010
	6-6	01-Dec-2010
	6-7	01-Dec-2010
	6-8	01-Dec-2010
	6-9	01-Dec-2010
	6-10	01-Dec-2010
	6-11	01-Dec-2010
	6-12	01-Dec-2010
	6-13	01-Dec-2010
	6-14	01-Dec-2010
	6-15	01-Dec-2010
	6-16	01-Dec-2010
	6-17	31-Jan-2014
	6-18	31-Jan-2014
	6-19	31-Jan-2014
	6-20	31-Jan-2014
	6-21	31-Jan-2014
	6-22	31-Jan-2014
	6-23	31-Jan-2014
	6-24	31-Jan-2014
	6-25	31-Jan-2014
	6-26	31-Jan-2014
	6-27	31-Jan-2014

Ch.	Page	Date
6	6-28	31-Jan-2014
	6-29	31-Jan-2014
	6-30	31-Jan-2014
	6-31	31-Jan-2014
	6-32	31-Jan-2014
	6-33	31-Jan-2014
	6-34	31-Jan-2014

Ch.	Page	Date
7	7-1	31-Jan-2014
	7-2	31-Jan-2014
	7-3	01-Dec-2010
	7-4	01-Dec-2010
	7-5	01-Dec-2010
	7-6	01-Dec-2010
	7-7	01-Dec-2010
	7-8	01-Dec-2010
	7-9	01-Dec-2010
	7-10	01-Dec-2010
	7-11	01-Dec-2010
	7-12	01-Dec-2010
	7-13	01-Dec-2010
	7-14	01-Dec-2010
	7-15	31-Jan-2014
	7-16	31-Jan-2014
	7-17	31-Jan-2014
	7-18	31-Jan-2014
	7-19	31-Jan-2014
	7-20	31-Jan-2014
	7-21	31-Jan-2014
	7-22	31-Jan-2014
	7-23	31-Jan-2014
	7-24	31-Jan-2014
	7-25	31-Jan-2014
	7-26	31-Jan-2014
	7-27	31-Jan-2014

Ch.	Page	Date
7	7-28	31-Jan-2014
	7-29	31-Jan-2014
	7-30	31-Jan-2014
	7-31	31-Jan-2014
	7-32	31-Jan-2014
	7-33	31-Jan-2014
	7-34	31-Jan-2014
	7-35	31-Jan-2014
	7-36	31-Jan-2014
	7-37	31-Jan-2014
	7-38	31-Jan-2014
	7-39	31-Jan-2014
	7-40	31-Jan-2014
	7-41	31-Jan-2014
	7-42	31-Jan-2014
	7-43	31-Jan-2014
	7-44	31-Jan-2014
	7-45	31-Jan-2014
	7-46	31-Jan-2014
	7-47	31-Jan-2014
	7-48	31-Jan-2014
	7-49	31-Jan-2014
	7-50	31-Jan-2014
	7-51	31-Jan-2014
	7-52	31-Jan-2014
	7-53	31-Jan-2014
	7-54	31-Jan-2014

Ch.	Page	Date
7	7-55	31-Jan-2014
	7-56	31-Jan-2014
	7-57	31-Jan-2014
	7-58	31-Jan-2014

Ch.	Page	Date
9	9-1	01-Dec-2010
	9-2	01-Dec-2010
	9-3	01-Dec-2010
	9-4	01-Dec-2010
	9-5	01-Dec-2010
	9-6	01-Dec-2010

Ch.	Page	Date
8	8-1	01-Dec-2010
	8-2	01-Dec-2010
	8-3	01-Dec-2010
	8-4	01-Dec-2010
	8-5	01-Dec-2010
	8-6	01-Dec-2010
	8-7	01-Dec-2010
	8-8	01-Dec-2010
	8-9	01-Dec-2010
	8-10	01-Dec-2010
	8-11	01-Dec-2010
	8-12	01-Dec-2010

0.4 TABLE OF CONTENTS

	Chapter
GENERAL	
(a non-approved chapter)	1
OPERATING LIMITATIONS	
(an approved chapter)	2
EMERGENCY PROCEDURES	
(a non-approved chapter)	3
NORMAL OPERATING PROCEDURES	
(a non-approved chapter)	4A
ABNORMAL OPERATING PROCEDURES	
(a non-approved chapter)	4B
PERFORMANCE	
(a non-approved chapter)	5
MASS AND BALANCE / EQUIPMENT LIST	
(a non-approved chapter)	6
DESCRIPTION OF THE AIRPLANE AND ITS SYSTEMS	
(a non-approved chapter)	7
AIRPLANE HANDLING, CARE AND MAINTENANCE	
(a non-approved chapter)	8
SUPPLEMENTS	9

CHAPTER 1

GENERAL

	Page
1.1 INTRODUCTION	1-2
1.2 CERTIFICATION BASIS	1-5
1.3 WARNINGS, CAUTIONS AND NOTES	1-5
1.4 DIMENSIONS	1-6
1.5 DEFINITIONS AND ABBREVIATIONS	1-8
1.6 UNITS OF MEASUREMENT	1-18
1.6.1 CONVERSION FACTORS	1-18
1.6.2 CONVERSION CHART LITERS / US GALLONS	1-20
1.7 THREE-VIEW DRAWING	1-21
1.8 SOURCE DOCUMENTATION	1-22
1.8.1 ENGINE	1-22
1.8.2 PROPELLER	1-23
1.8.3 ENGINE INSTRUMENTS	1-23
1.8.4 IGNITION CONTROL UNIT	1-24

1.1 INTRODUCTION

This Airplane Flight Manual has been prepared in order to provide pilots and instructors with all the information required for the safe and efficient operation of the airplane.

The Airplane Flight Manual includes all the data which must be made available to the pilot according to the JAR-23 requirement. Beyond this, it contains further data and operating instructions which, in the manufacturer's opinion, could be of value to the pilot.

This Airplane Flight Manual is valid for all serial numbers. Equipment and modification level (design details) of the airplane may vary from serial number to serial number. Therefore, some of the information contained in this manual is applicable depending on the respective equipment and modification level. The exact equipment of your serial number is recorded in the Equipment Inventory in Section 6.5. The modification level is recorded in the following table (as far as necessary for this manual).

Modification	Source	Installed	
RH Emergency Window	MÄM 40-048	<input type="checkbox"/> yes	<input checked="" type="checkbox"/> no
Modified MLG Strut	MÄM 40-123/e	<input checked="" type="checkbox"/> yes	<input type="checkbox"/> no
1200 kg Maximum Take-Off Mass	MÄM 40-227	<input checked="" type="checkbox"/> yes	<input type="checkbox"/> no
Autopilot	OÄM 40-061	<input checked="" type="checkbox"/> yes	<input type="checkbox"/> no
Tow-Plane Operation	OÄM 40-063/b	<input type="checkbox"/> yes	<input checked="" type="checkbox"/> no
Emergency Switch	OÄM 40-067	<input checked="" type="checkbox"/> yes	<input type="checkbox"/> no
Essential Bus	OÄM 40-068	<input checked="" type="checkbox"/> yes	<input type="checkbox"/> no
Long Range Tank	OÄM 40-071/b	<input checked="" type="checkbox"/> yes	<input type="checkbox"/> no
Alternate Static Valve	OÄM 40-072	<input checked="" type="checkbox"/> yes	<input type="checkbox"/> no
SlickSTART Ignition System	OÄM 40-073	<input checked="" type="checkbox"/> yes	<input type="checkbox"/> no
MT P-420-10 Governor	OÄM 40-077	<input type="checkbox"/> yes	<input checked="" type="checkbox"/> no
Operation with Winter Kit	OÄM 40-078	<input checked="" type="checkbox"/> yes	<input type="checkbox"/> no

Modification	Source	Installed	
Door Locking System	OÄM 40-081	<input checked="" type="checkbox"/> yes	<input type="checkbox"/> no
NLG Speedkit	OÄM 40-105	<input type="checkbox"/> yes	<input checked="" type="checkbox"/> no
MLG Speedkit	OÄM 40-106	<input type="checkbox"/> yes	<input checked="" type="checkbox"/> no
Essential Tie Relay Bypass	OÄM 40-126	<input type="checkbox"/> yes	<input checked="" type="checkbox"/> no
Baggage Extension	OÄM 40-163	<input checked="" type="checkbox"/> yes	<input type="checkbox"/> no
Baggage Tray*	OÄM 40-164	<input checked="" type="checkbox"/> yes	<input type="checkbox"/> no
Winter Baffle Fresh Air Inlet	OÄM 40-183	<input checked="" type="checkbox"/> yes	<input type="checkbox"/> no
Nose Landing Gear Tie-Down	OÄM 40-200	<input type="checkbox"/> yes	<input checked="" type="checkbox"/> no
Electrical Rudder Pedal Adjustment	OÄM 40-251	<input type="checkbox"/> yes	<input checked="" type="checkbox"/> no
Front Seats with Adjustable Backrest	OÄM 40-252	<input type="checkbox"/> yes	<input checked="" type="checkbox"/> no
CO Monitor	OÄM 40-253	<input type="checkbox"/> yes	<input checked="" type="checkbox"/> no
Autopilot Static Source	OÄM 40-267	<input checked="" type="checkbox"/> yes	<input type="checkbox"/> no
Tall Main Landing Gear	OÄM 40-283	<input type="checkbox"/> yes	<input checked="" type="checkbox"/> no
ELT Artex ME 406 'ACE'	OÄM 40-284	<input type="checkbox"/> yes	<input checked="" type="checkbox"/> no
MT P-860-23 Governor	OÄM 40-289	<input type="checkbox"/> yes	<input checked="" type="checkbox"/> no
Emergency Axe	OÄM 40-326	<input type="checkbox"/> yes	<input checked="" type="checkbox"/> no

*For installation of the Baggage Tray the Baggage Extension must be installed.

This Airplane Flight Manual must be kept on board the airplane at all times. Its designated place is the side bag of the forward left seat.

This Airplane Flight Manual constitutes an FAA Approved Airplane Flight Manual for US registered airplanes in accordance with FAA regulation 14 CFR, Part 21.29.

1200kg max Take-off Mass : MÄM 40-227

Revision installed 2017

CAUTION

The DA 40 is a single engine airplane. When the operating limitations and maintenance requirements are complied with, it has the high degree of reliability which is required by the certification basis. Nevertheless, an engine failure is not completely impossible. For this reason, flights during the night, on top, under instrument meteorological conditions (IMC), or above terrain which is unsuitable for a landing, constitute a risk. It is therefore highly recommended to select flight times and flight routes such that this risk is minimized.

1.2 CERTIFICATION BASIS

This airplane has been type certified in accordance with the JAA JC/VP procedure. The certification basis is JAR-23, published on 11-Mar-1994.

1.3 WARNINGS, CAUTIONS AND NOTES

Special statements in the Airplane Flight Manual concerning the safety or operation of the airplane are highlighted by being prefixed by one of the following terms:

WARNING

means that the non-observation of the corresponding procedure leads to an immediate or important degradation in flight safety.

CAUTION

means that the non-observation of the corresponding procedure leads to a minor or to a more or less long term degradation in flight safety.

NOTE

draws the attention to any special item not directly related to safety but which is important or unusual.

1.4 DIMENSIONS

Overall Dimensions

Span	:	appr. 11.94 m	appr. 39 ft 2 in
Length	:	appr. 8.01 m	appr. 26 ft 3 in
Height	:	appr. 1.97 m	appr. 6 ft 6 in

Wing

Airfoil	:	Wortmann FX 63-137/20 - W4	
Wing Area	:	appr. 13.54 m ²	appr. 145.7 sq.ft.
Mean aerodynamic chord (MAC)	:	appr. 1.121 m	appr. 3 ft 8.1 in
Aspect ratio	:	appr. 10.53	
Dihedral	:	appr. 5°	
Leading edge sweep	:	appr. 1°	

Aileron

Area (total, left + right)	:	appr. 0.654 m ²	appr. 7.0 sq.ft.
----------------------------	---	----------------------------	------------------

Wing Flaps

Area (total, left + right)	:	appr. 1.56 m ²	appr. 16.8 sq.ft.
----------------------------	---	---------------------------	-------------------

Horizontal Tail

Area	:	appr. 2.34 m ²	appr. 25.2 sq.ft.
Elevator area	:	appr. 0.665 m ²	appr. 7.2 sq.ft.
Angle of incidence	:	appr. -3.0° relative to longitudinal axis of airplane	

Vertical Tail

Area	:	appr. 1.60 m ²	appr. 17.2 sq.ft.
Rudder area	:	appr. 0.47 m ²	appr. 5.1 sq.ft.

Landing Gear

Track	:	appr. 2.97 m	appr. 9 ft 9 in
Wheelbase	:	appr. 1.68 m	appr. 5 ft 6 in

Nose wheel : 5.00-5; 6 PR, 120 mph

Main wheel : (a) 6.00-6; 6 PR, 120 mph in combination with any MLG strut

(b) 15 x 6.0-6; 6 PR, 160 mph;
Only in combination with "thin"
[MÄM 140-23/e] or "tall" (40-283) MLG strut

~~(b) 6.00-6; 8 PR, 120 mph in combination with any MLG strut~~

~~(c) 15 x 6.0-6; 6 PR, 160 mph~~

~~(OÄM 40-124; only in combination with the "thin"/"18 mm" [MÄM 40-123] or the "tall"~~

~~[OÄM 40-283] MLG strut)~~

1.5 DEFINITIONS AND ABBREVIATIONS

(a) Airspeeds

CAS: Calibrated Airspeed. Indicated airspeed, corrected for installation and instrument errors. CAS equals TAS at standard atmospheric conditions at MSL.

IAS: Indicated Airspeed as shown on an airspeed indicator.

KCAS: CAS in knots.

KIAS: IAS in knots.

TAS: True Airspeed. The speed of the airplane relative to the air. TAS is CAS corrected for errors due to altitude and temperature.

V_A : Maneuvering Speed. Full or abrupt control surface movement is not permissible above this speed.

V_{FE} : Max. Flaps Extended Speed. This speed must not be exceeded with the given flap setting.

V_{NE} : Never Exceed Speed in smooth air. This speed must not be exceeded in any operation.

V_{NO} Maximum Structural Cruising Speed. This speed may be exceeded only in smooth air, and then only with caution.

V_S : Stalling Speed, or the minimum continuous speed at which the airplane is still controllable in the given configuration.

V_{S0} : Stalling Speed, or the minimum continuous speed at which the airplane is still controllable in the landing configuration.

V_x : Best Angle-of-Climb Speed.

V_y : Best Rate-of-Climb Speed.

(b) Meteorological Terms

ISA: International Standard Atmosphere. Conditions at which air is identified as an ideal dry gas. The temperature at mean sea level is 15 °C (59 °F), air pressure at MSL is 1013.25 hPa (29.92 inHg); the temperature gradient up to the altitude at which the temperature reaches -56.5 °C (-69.7 °F) is -0.0065 °C/m (-0.00357 °F/ft), and above this 0 °C/m (0 °F/ft).

MSL: Mean Sea Level.

OAT: Outside Air Temperature.

QNH: Theoretical atmospheric pressure at MSL, calculated from the elevation of the measuring point above MSL and the actual atmospheric pressure at the measuring point.

Indicated Pressure Altitude:

Altitude reading with altimeter set to 1013.25 hPa (29.92 inHg).

Pressure Altitude: Altitude above MSL, indicated by a barometric altimeter which is set to 1013.25 hPa (29.92 inHg). The Pressure Altitude is the Indicated Pressure Altitude corrected for installation and instrument errors.

In this Airplane Flight Manual altimeter instrument errors are regarded as zero.

Density Altitude: Altitude in ISA conditions at which the air density is equal to the current air density.

Wind: The wind speeds which are shown as variables in the diagrams in this manual should be regarded as headwind or downwind components of the measured wind.

(c) Flight Performance and Flight Planning

Demonstrated Crosswind Component:

The speed of the crosswind component at which adequate maneuverability for take-off and landing has been demonstrated during type certification.

MET: Weather, weather advice.

NAV: Navigation, route planning.

(d) Mass and Balance (M&B, W&B)

DP: Datum Plane; an imaginary vertical plane from which all horizontal distances for center of gravity calculations are measured.

Moment Arm: The horizontal distance from the Datum Plane to the Center of Gravity of a component.

Moment: The mass of a component multiplied by its moment arm.

CG: Center of Gravity, also called 'center of mass'. Imaginary point in which the airplane mass is assumed to be concentrated for mass and balance calculations. Its distance from the Datum Plane is equal to the Center of Gravity Moment Arm.

Center of Gravity Moment Arm:

The Moment Arm which is obtained if one divides the sum of the individual moments of the airplane by its total mass.

Center of Gravity Limits:

The Center of Gravity range within which the airplane, at a given mass, must be operated.

Usable Fuel: The quantity of fuel available for flight planning.

Unusable Fuel: The quantity of fuel remaining in the tank which cannot be used for flight.

Empty Mass: The mass of the airplane including unusable fuel, all operating consumables and the maximum quantity of oil.

Useful Load: The difference between take-off mass and empty mass.

Maximum Take-off Mass:

The maximum permissible mass for take-off.

Maximum Landing Mass:

The highest mass for landing conditions at the maximum descent velocity. This velocity was used in the strength calculations to determine the landing gear loads during a particularly hard landing.

(e) Engine

Take-off Power:

Maximum permissible engine output power for take-off.

Maximum Continuous Power:

Maximum permissible engine output power used continuously during flight.

CHT: Cylinder Head Temperature.

EGT: Exhaust Gas Temperature.

(f) Designation of the Circuit Breakers on the Instrument Panel*Asymmetric Instrument Panel (Circuit Breakers Right Hand)***AVIONICS:**

ADF	Automatic Direction Finder
AUDIO	Audio Panel / Intercom
AUTOPILOT	Autopilot
AVIONIC BUS	Avionic Bus
DME	Distance Measuring Equipment
ESSENTIAL AVIONIC	Essential Avionic Bus
GPS	Global Positioning System
GPS2	Global Positioning System #2
NAV/COM1	Navigation/Communication #1
NAV/COM2	Navigation/Communication #2
STRIKE	Strike Finder
XPDR	Transponder

ENGINE:

IGNITION	Ignition
INST. 1	Engine Instrument VM 1000
START	Starter

LIGHTING:

FLOOD	Flood Light
INST.	Instrument Lights
LANDING	Landing Light
POSITION	Position Lights
STROBE	Strobe Light (=Anti Collision Light = ACL)
TAXI/MAP	Taxi Light/Map Light

SYSTEMS:

ANNUN.	Annunciator Panel
DG	Directional Gyro
FAN/OAT	Fan/Outside Air Temperature Indicator
FLAPS	Flaps
FUEL PUMP	Fuel Pump
HORIZON	Artificial Horizon (Attitude Gyro)
PITOT HEAT	Pitot Heating System
T&B	Turn & Bank Indicator

ELECTRICAL:

ALT.	Alternator
ALT. CONT.	Alternator Control
ALT. PROT.	Alternator Protection
BATT.	Battery
ESSENTIAL TIE	Bus Interconnection
MAIN TIE	Bus Interconnection
MASTER CONTROL	Master Control (avionic master switch, essential bus switch, essential avionics relay, bus interconnection relay, avionics master relay)

*Symmetric Instrument Panel (Circuit Breakers Bottom Side)**MAIN BUS:*

ALT.	Alternator
ALT. CONT.	Alternator Control
ALT. PROT.	Alternator Protection
AV. BUS	Avionic Bus
DG	Directional Gyro
FAN/OAT	Fan/Outside Air Temperature Indicator
FUEL PUMP	Fuel Pump
IGNITION	Ignition
INST.	Instrument Lights
MAIN TIE	Bus Interconnection
POSITION	Position Lights
START	Starter
STROBE	Strobe Lights (Anti Collision Lights, ACLs)
T & B	Turn & Bank Indicator
TAXI/MAP	Taxi Light/Map Light

MAIN AV. BUS (Main Avionic Bus):

ADF	Automatic Direction Finder
AUDIO	Audio Panel / Intercom
AUTO PILOT	Autopilot
COM2	Communication #2
COM/NAV2	Communication / Navigation #2
DME	Distance Measuring Equipment
GPS2	Global Positioning System #2
GPS/NAV2	Global Positioning System/Navigation #2
STRIKE	Strike Finder
Wx 500	Stormscope
TAS	Traffic Advisory System

ESS. AV. BUS (Essential Avionic-Bus):

COM1	Communication #1
COM/NAV1	Communication/Navigation #1
GPS1	Global Positioning System #1
GPS/NAV1	Global Positioning System/Navigation #1
XPDR	Transponder

ESSENTIAL BUS:

ANNUN.	Annunciator Panel
BATT.	Battery
ESS. AV.	Essential Avionic-Bus
ESS TIE	Bus Interconnection
FLAPS	Flaps
FLOOD	Flood Light
HORIZON	Artificial Horizon (Attitude Gyro)
INST. 1	Engine Instrument VM 1000
LANDING	Landing Light
MASTER CONTROL	Master Control (avionic master switch, essential bus switch, essential avionics relay, bus interconnection relay, avionics master relay)
PITOT	Pitot Heating System

(g) Equipment

ELT: Emergency Locator Transmitter.

(h) Design Change Advisories

MÄM: Mandatory Design Change Advisory.

OÄM: Optional Design Change Advisory.

(i) Miscellaneous

ACG: Austro Control GmbH (formerly BAZ, Federal Office of Civil Aviation).

ATC: Air Traffic Control.

CFRP: Carbon Fiber Reinforced Plastic.

GFRP: Glass Fiber Reinforced Plastic.

JAR: Joint Aviation Requirements.

JC/VP: Joint Certification/Validation Procedure.

PCA: Primary Certification Authority.

1.6 UNITS OF MEASUREMENT

1.6.1 CONVERSION FACTORS

Dimension	SI-Units	US Units	Conversion
Length	[mm] millimeters	[in] inches	$[mm] / 25.4 = [in]$
	[m] meters	[ft] feet	$[m] / 0.3048 = [ft]$
	[km] kilometers	[NM] nautical miles	$[km] / 1.852 = [NM]$
Volume	[l] liters	[US gal] US gallons	$[l] / 3.7854 = [US\ gal]$
		[qts] US quarts	$[l] / 0.9464 = [qts]$
Speed	[km/h] kilometers per hour	[kts] knots	$[km/h] / 1.852 = [kts]$
	[m/s] meters per second	[mph] miles per hour	$[km/h] / 1.609 = [mph]$
		[fpm] feet per minute	$[m/s] \times 196.85 = [fpm]$
Speed of rotation	[RPM] revolutions per minute		--
Mass	[kg] kilograms	[lb] pounds	$[kg] \times 2.2046 = [lb]$
Force, weight	[N] newtons	[lbf] pounds force	$[N] \times 0.2248 = [lbf]$
Pressure	[hPa] hecto-pascals	[inHg] inches of mercury	$[hPa] = [mbar]$
	[mbar] millibars	[psi] pounds per square inch	$[hPa] / 33.86 = [inHg]$
	[bar] bars		$[bar] \times 14.504 = [psi]$
Temperature	[°C] degrees Celsius	[°F] degrees Fahrenheit	$[°C] \times 1.8 + 32 = [°F]$ $([°F] - 32) / 1.8 = [°C]$

Dimension	SI-Units	US Units	Conversion
Intensity of electric current	[A] ampères		--
Electric charge (battery capacity)	[Ah] ampère-hours		--
Electric potential	[V] volts		--
Time	[sec] seconds		--

1.6.2 CONVERSION CHART LITERS / US GALLONS

Liters	US Gallons
5	1.3
10	2.6
15	4.0
20	5.3
25	6.6
30	7.9
35	9.2
40	10.6
45	11.9
50	13.2
60	15.9
70	18.5
80	21.1
90	23.8
100	26.4
110	29.1
120	31.7
130	34.3
140	37.0
150	39.6
160	42.3
170	44.9
180	47.6

US Gallons	Liters
1	3.8
2	7.6
4	15.1
6	22.7
8	30.3
10	37.9
12	45.4
14	53.0
16	60.6
18	68.1
20	75.7
22	83.3
24	90.9
26	98.4
28	106.0
30	113.6
32	121.1
34	128.7
36	136.3
38	143.8
40	151.4
45	170.3
50	189.3

1.7 THREE-VIEW DRAWING

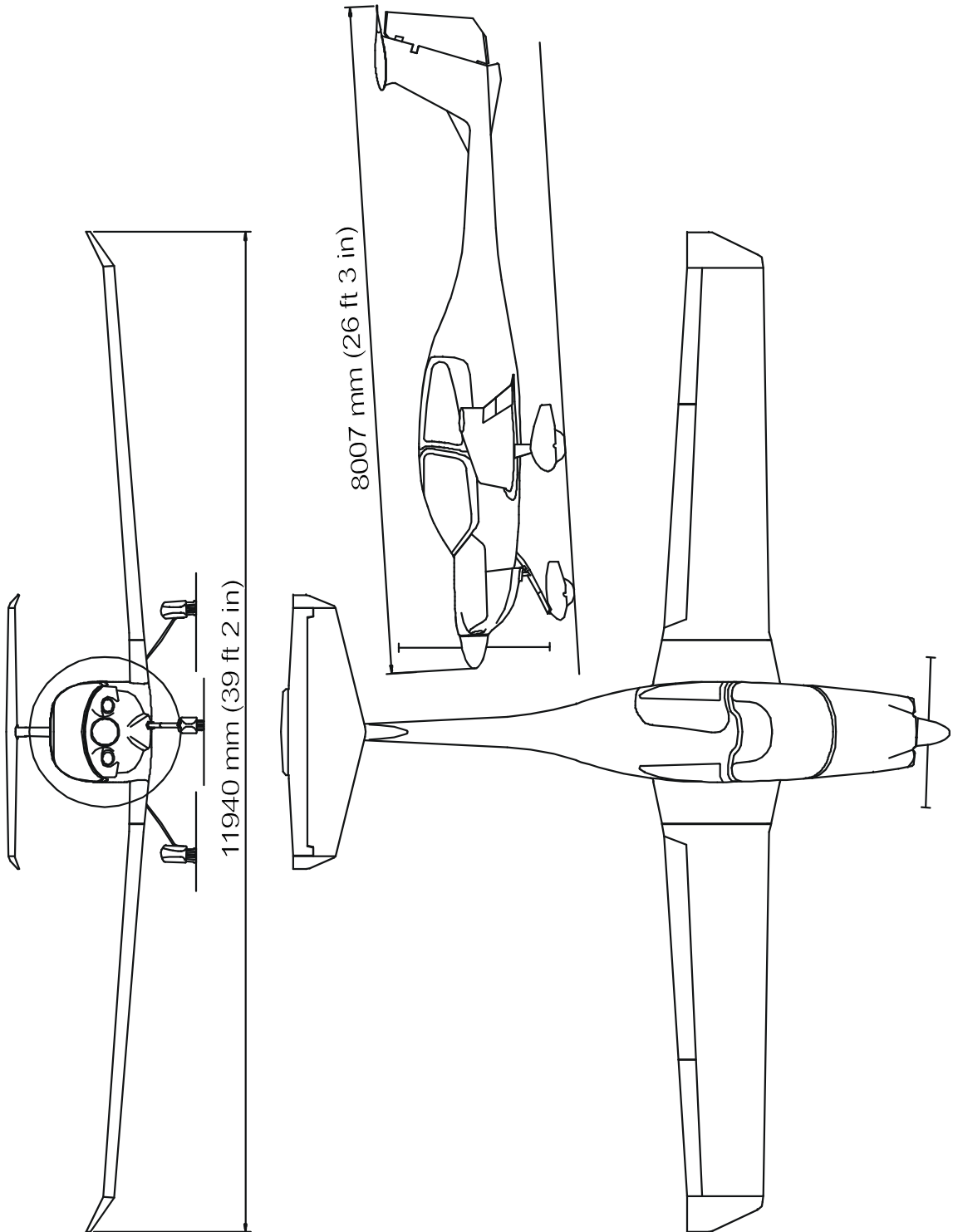

1.8 SOURCE DOCUMENTATION

This Section lists documents, manuals and other literature that were used as sources for the Airplane Flight Manual, and indicates the respective publisher. However, only the information given in the Airplane Flight Manual is valid.

1.8.1 ENGINE

Address: Textron Lycoming
652 Oliver Street
WILLIAMSPORT, PA 17701
USA

Phone: +1-570-323-6181

Webpage: www.lycoming.textron.com

Documents: a) Textron Lycoming Operator's Manual, Aircraft Engines
60297-12 (Part No.)
b) Service Bulletins (SB)
Service Instructions (SI); (e.g. SI 1014, SI 1070)
Service Letters (SL); (e.g. SL114 (subscriptions))

1.8.2 PROPELLER

Address: mt-Propeller
Airport Straubing Wallmühle
D-94348 ATTING
GERMANY

Phone: +49-9429-9409-0
E-mail: sales@mt-propeller.com
Webpage: www.mt-propeller.de

Documents: E-124, Operation and Installation Manual
Hydraulically controlled variable pitch propeller
MTV -5, -6, -9, -11, -12, -14, -15, -16, -21, -22, -25

1.8.3 ENGINE INSTRUMENTS

Address: VISION MICROSYSTEMS, INC.
ADVANCED ELECTRONIC INSTRUMENTATION
4071 Hannegan Road, Suite T
BELLINGHAM, WA 98226
USA

Phone: +1-360-714-8203

Documents: 5010002 REV F, VM 1000 Owner's Manual

1.8.4 IGNITION CONTROL UNIT

The electronic ignition control unit LASAR is optional equipment.

Address: UNISON Industries
7575 Baymeadows Way
JACKSONVILLE, FL 32256
USA

Phone: +1-904-739-4066

Webpage: www.unisonindustries.com

Documents: L-1502
LASAR Installation, Operation, and Troubleshooting Manual

CHAPTER 2 OPERATING LIMITATIONS

	Page
2.1 INTRODUCTION	2-2
2.2 AIRSPEED	2-3
2.3 AIRSPEED INDICATOR MARKINGS	2-4
2.4 POWER-PLANT LIMITATIONS	2-5
2.5 ENGINE INSTRUMENT MARKINGS	2-7
2.6 WARNING, CAUTION AND STATUS LIGHTS	2-9
2.7 MASS (WEIGHT)	2-11
2.8 CENTER OF GRAVITY	2-13
2.9 APPROVED MANEUVERS	2-14
2.10 MANEUVERING LOAD FACTORS	2-16
2.11 OPERATING ALTITUDE	2-17
2.12 FLIGHT CREW	2-17
2.13 KINDS OF OPERATION	2-18
2.14 FUEL	2-22
2.15 LIMITATION PLACARDS	2-24
2.16 OTHER LIMITATIONS	2-32
2.16.1 TEMPERATURE	2-32
2.16.2 BATTERY CHARGE	2-32
2.16.3 EMERGENCY SWITCH	2-32
2.16.4 OPERATION TIME OF ELECTRICAL EQUIPMENT	2-32
2.16.5 DOOR LOCKING DEVICE	2-33
2.16.6 ELECTRONIC EQUIPMENT	2-33
2.16.7 USE OF THE SUN VISORS	2-33

2.1 INTRODUCTION

Chapter 2 of this Airplane Flight Manual includes operating limitations, instrument markings, and placards necessary for safe operation of the airplane, its power-plant, standard systems and standard equipment.

The limitations included in this Chapter are approved.

WARNING

Operation of the airplane outside of the approved operating limitations is not permissible.

Temporary Revision: TR-MAM-40-227
1200kg Max Take off mass

2.2 AIRSPEED

	Airspeed	IAS	Remarks
V_A	Maneuvering speed	 108 KIAS (above 980 kg / 2161 lb up to 1150 kg / 2535 lb) 94 KIAS (780 kg / 1720 lb up to 980 kg / 2161 lb) <div style="border: 1px solid green; padding: 5px;"> If MÄM 40-227 is carried out: 111 KIAS (above 1036 kg / 2284 lb up to 1200 kg / 2646 lb) 94 KIAS (780 kg / 1720 lb up to 1036 kg / 2284 lb) </div>	Do not make full or abrupt control surface movement above this speed.
V_{FE}	Max. flaps extended speed	LDG: 91 KIAS T/O: 108 KIAS	Do not exceed these speeds with the given flap setting.
V_{NO} = V_C	Max. structural cruising speed	129 KIAS	Do not exceed this speed except in smooth air, and then only with caution.
V_{NE}	Never exceed speed in smooth air	178 KIAS	Do not exceed this speed in any operation.

2.3 AIRSPEED INDICATOR MARKINGS

Marking	IAS	Significance
White arc	49 KIAS - 91 KIAS	Operating range with flaps fully extended.
Green arc	52 KIAS - 129 KIAS	Normal operating range.
Yellow arc	129 KIAS - 178 KIAS	'Caution' range - "Only in smooth air".
Red line	178 KIAS	Maximum speed for all operations - V_{NE} .

2.4 POWER-PLANT LIMITATIONS

- a) Engine manufacturer : Textron Lycoming
- b) Engine designation : IO-360 M1-A
- c) RPM limitations
- Max. take-off RPM : 2700 RPM
 - Max. continuous RPM : 2400 RPM
- d) Manifold pressure limitations
- Maximum : FULL throttle
- e) Oil pressure
- Minimum (IDLE) : 25 PSI / 1.72 bar
 - Maximum : 98 PSI / 6.76 bar
 - Normal operating range : 55 to 95 PSI / 3.8 to 6.55 bar
- f) Oil quantity
- Minimum : 4 qts
 - Maximum : 8 qts
- g) Oil temperature
- Maximum : 245 °F (118 °C)
- h) Fuel pressure
- Minimum : 14 PSI / 0.97 bar
 - Maximum : 35 PSI / 2.4 bar
- i) Cylinder head temperature
- Maximum : 500 °F (260 °C)
- j) Propeller manufacturer : mt-Propeller

- k) Propeller designation : MTV-12-B/180-17 or
MTV-12-B/180-17f
- l) Propeller diameter : 1.80 m (+ 0 mm, - 50 mm)
5 ft 10.9 in (+ 0.0 in, - 2.0 in)
- m) Propeller pitch angle (0.75 R) : 10.5° to 30°
- n) Oil specification:

Airplane engine oil should be used which meets SAEJ1899 (MIL-L-22851) Standard (ashless dispersant type). During the first 50 hours of operation of a new or newly overhauled engine, or after replacement of a cylinder, airplane engine oil should be used which meets SAEJ1966 (MIL-L-6082) Standard (straight mineral type). The viscosity should be selected according to the recommendation given in the following table:

OAT at Ground Level	<i>During the first 50 hours:</i> SAEJ1966 / MIL-L-6082 Mineral Oil	<i>After 50 hours:</i> SAEJ1899 / MIL-L-22851 Ashless Dispersant Oil
All temperatures	---	SAE 15-W50, SAE 20-W50
above 80 °F (above 27 °C)	SAE 60	SAE 60
above 60 °F (above 16 °C)	SAE 50	SAE 40 or SAE 50
30 °F to 90 °F (-1 °C to 32 °C)	SAE 40	SAE 40
0 °F to 90 °F (-18 °C to 32 °C)	SAE 20-W50	SAE 20-W50 or SAE 15-W50
0 °F to 70 °F (-18 °C to 21 °C)	SAE 30	SAE 30, SAE 40, or SAE 20-W40
below 10 °F (below -12 °C)	SAE 20	SAE 30 or SAE 20-W30

2.5 ENGINE INSTRUMENT MARKINGS

Engine instrument markings and their color code significance are shown in the table below:

NOTE

When an indication lies in the upper or lower prohibited range, the numerical indication will begin flashing as well.

Indi- cation	Red arc/bar = lower prohibited range	Yellow arc/bar = caution range	Green arc/bar = normal operating range	Yellow arc/bar = caution range	Red arc/bar = upper prohibited range
Manifold pressure	--	--	13 - 30 inHg	--	--
RPM	--	--	500 - 2400 RPM	2400 - 2700 RPM	above 2700 RPM
Oil temp.	--	--	149 - 230 °F	231 - 245 °F	above 245 °F
Cylinder head temp.	--	--	150 - 475 °F	476 - 500 °F	above 500 °F
Oil pressure	below 25 PSI	25 - 55 PSI	56 - 95 PSI	96 - 97 PSI	above 97 PSI
Fuel pressure	below 14 PSI	--	14 - 35 PSI	--	above 35 PSI
Fuel flow	--	--	1 - 20 US gal/hr	--	above 20 US gal/hr
Voltage	below 24.1 V	24.1 - 25 V	25.1 - 30 V	30.1 - 32 V	above 32 V
Ammeter	--	--	2 - 75 A	--	--

Indi- cation	Red arc/bar = lower prohibited range	Yellow arc/bar = caution range	Green arc/bar = normal operating range	Yellow arc/bar = caution range	Red arc/bar = upper prohibited range
Fuel quantity, Standard Tank	0 US gal	--	0 - 15 US gal ¹ 0 - 17 US gal ²	--	--
Fuel quantity, Long Range Tank	0 US gal	--	0 - 16 US gal + 0 - 9 US gal ³	--	--

¹ up to and including serial number 40.054

² serial number 40.055 and subsequent

³ numerical indication of the *additional* (auxiliary) fuel quantity, for a total fuel quantity on one side in the range between 16 and 25 US gal

2.6 WARNING, CAUTION AND STATUS LIGHTS

The following tables show the color and significance of the warning, caution and status lights on the annunciator panel. There are two variants of the annunciator panel, 'DAI' and 'White Wire' (see Section 7.11).

NOTE

Section 7.11 includes a detailed description of the lights on the annunciator panel.

Color and Significance of the Warning Lights (Red)

Warning Lights (Red)			Cause
Variant 'DAI'	Variant 'White Wire'	Meaning	
OIL PR	OIL PRESS	Oil pressure	Oil pressure below 25 PSI
FUEL PR	FUEL PRESS	Fuel pressure	Fuel pressure below 14 PSI
ALT	ALTERNATOR	Alternator (Generator)	Alternator failure
START	START	Starter	Operation of starter, or failure of the starter motor to disengage from the engine after starting
DOOR	DOORS	Doors	Front canopy and/or rear door not completely closed and locked
	TRIM FAIL	Trim failure	Failure in the automatic trim system of the autopilot (if installed)

Color and Significance of the Caution Lights (Amber)

Caution Lights (Amber)			Cause
Variant 'DAI'	Variant 'White Wire'	Meaning	
L FUEL		Fuel quantity left tank	Fuel quantity in the left tank less than 3 US gal (± 1 US gal)
R FUEL		Fuel quantity right tank	Fuel quantity in the right tank less than 3 US gal (± 1 US gal)
	LOW FUEL	Fuel quantity	1 st caution: fuel quantity in one tank less than 3 US gal (± 1 US gal) 2 nd caution: fuel quantity in second tank less than 3 US gal (± 1 US gal)
VOLT	LOW VOLTS	Voltage	On-board voltage below 24 V
PITOT	PITOT	Pitot heating	Pitot heating not switched ON, or fault in the Pitot heating system

Color and Significance of the Status Light (White)

Status Light (White)			Cause
Variant 'DAI'	Variant 'White Wire'	Meaning	
IGN	IGNITION	Ignition	Electronic ignition control unit (if installed) not in operation

Revision 2.7: Mass (weight)

Max Take off Mass: 1200kg; 2646lbs

Page 2 - 10	Rev. 8	01-Dec-2010	EASA approved	Doc. # 6.01.01-E
-------------	--------	-------------	---------------	------------------

2.7 MASS (WEIGHT)

Maximum take-off mass (Normal Category)	: 1150 kg	2535 lb
if MÄM 40-227 is carried out	: 1200 kg	2646 lb
Maximum take-off mass (Utility Category)	: 980 kg	2161 lb
Maximum landing mass		
Original MLG strut	: 1092 kg	2407 lb
Modified MLG strut		
(MÄM 40-123/e or OÄM 40-283)	: 1150 kg	2535 lb
Maximum zero fuel mass	: 1150 kg	2535 lb
Max. load in standard baggage compartment	: 30 kg	66 lb
Max. load in baggage tube	: 5 kg	11 lb
Max. load in extended baggage compartment (OÄM 40-163)		
Max. load in forward part	: 45 kg	100 lb
Max. load in aft part	: 18 kg	40 lb
Max. total load forward + aft	: 45 kg	100 lb
Max. surface load for baggage compartments	: 75 kg/m ²	15.3 lb/ft ²

WARNING

Exceeding the mass limits will lead to an overstressing of the airplane as well as to a degradation of flight characteristics and flight performance.

NOTE

The maximum landing mass is the highest mass for landing conditions at the maximum descent velocity. This velocity was used in the strength calculations to determine the landing gear loads during a particularly hard landing.

NOTE

In some countries the beginning of a flight is defined by starting the engine. In those countries a maximum ramp mass 4 kg (9 lb) above the maximum take-off mass is approved. At the time of lift-off the maximum permitted take-off mass must not be exceeded.

2.8 CENTER OF GRAVITY

Datum Plane

The Datum Plane (DP) is a plane which is normal to the airplane's longitudinal axis and in front of the airplane as seen from the direction of flight. The airplane's longitudinal axis is parallel with the upper surface of a 600:31 wedge which is placed on top of the rear fuselage in front of the vertical stabilizer. When the upper surface of the wedge is aligned horizontally, the Datum Plane is vertical. The Datum Plane is located 2.194 meters (86.38 in) forward of the most forward point of the root rib on the stub wing.

Center of Gravity Limitations

The center of gravity (CG) for flight conditions must lie between the following limits:

Most forward CG:

2.40 m (94.5 in) aft of DP from 780 kg to 980 kg (1720 lb to 2161 lb)

2.46 m (96.9 in) aft of DP at 1150 kg (2535 lb)

linear variation between these values

If MÄM 40-227 is carried out:

2.40 m (94.5 in) aft of DP from 780 kg to 980 kg (1720 lb to 2161 lb)

2.48 m (97.6 in) aft of DP at 1200 kg (2646 lb)

linear variation between these values

Most rearward CG:

a) Standard Tank : 2.59 m (102.0 in) aft of DP

b) Long Range Tank : 2.55 m (100.4 in) aft of DP

WARNING

Exceeding the center of gravity limitations reduces the controllability and stability of the airplane.

2.9 APPROVED MANEUVERS

The airplane is certified in the Normal Category and in the Utility Category in accordance with JAR-23.

Approved Maneuvers

a) Normal Category:

- 1) All normal flight maneuvers;
- 2) Stalling (with the exception of dynamic stalling); and
- 3) Lazy Eights, Chandelles, as well as steep turns and similar maneuvers, in which an angle of bank of not more than 60° is attained.

CAUTION

Aerobatics, spinning, and flight maneuvers with more than 60° of bank are not permitted in the Normal Category.

b) Utility Category:

- 1) All normal flight maneuvers;
- 2) Stalling (with the exception of dynamic stalling); and
- 3) Lazy Eights, Chandelles, as well as steep turns and similar maneuvers, in which an angle of bank of not more than 90° is attained.

CAUTION

Aerobatics, spinning, and flight maneuvers with more than 90° of bank are not permitted in the Utility Category.

CAUTION

The accuracy of the attitude gyro (artificial horizon) and the directional gyro is affected by the maneuvers approved under item 3 if the bank angle exceeds 60°. Such maneuvers may therefore only be flown when the above mentioned instruments are not required for the present kind of operation.

2.10 MANEUVERING LOAD FACTORS

Table of maximum structural load factors:

Normal Category

	at v_A	at v_{NE}	With Flaps in T/O or LDG Position
Positive	3.8	3.8	2.0
Negative	-1.52	0	

Utility Category

	at v_A	at v_{NE}	With Flaps in T/O or LDG Position
Positive	4.4	4.4	2.0
Negative	-1.76	-1	

WARNING

Exceeding the maximum load factors will lead to an overstressing of the airplane.

2.11 OPERATING ALTITUDE

The maximum demonstrated operating altitude is 16,400 ft (5,000 m).

The maximum approved operating altitude for US registered airplanes is 14,000 ft MSL unless an approved supplemental oxygen system is installed.

2.12 FLIGHT CREW

Minimum crew number : 1 (one person)

Maximum number of occupants:

Normal Category : 4 (four persons)

Utility Category : 2 (two persons), both of whom must sit in front

2.13 KINDS OF OPERATION

Provided that national operational requirements are met, the following kinds of operation are approved:

- * Daytime flights according to Visual Flight Rules (VFR).
- * With the appropriate equipment: night flights according to Visual Flight Rules (NVFR).
- * With the appropriate equipment: flights according to Instrument Flight Rules (IFR).

Flights into known or forecast icing conditions are prohibited.

Flights into known thunderstorms are prohibited.

Minimum Operational Equipment (Serviceable)

The following table lists the minimum serviceable equipment required by JAR-23. Additional minimum equipment for the intended operation may be required by national operating rules and also depends on the route to be flown.

Page 2 - 18	Rev. 8	01-Dec-2010	EASA approved	Doc. # 6.01.01-E
-------------	--------	-------------	------------------	------------------

Minimum Operational Equipment (Serviceable)			
	For Daytime VFR Flights	In Addition for Night VFR Flights	In addition for IFR Flights
Flight and Navigation Instruments	<ul style="list-style-type: none"> * Airspeed indicator * Altimeter * Magnetic compass 	<ul style="list-style-type: none"> * Vertical speed indicator (VSI) * Attitude gyro (artificial horizon) * Turn & bank indicator * Directional gyro * OAT indicator * Chronometer with indication of hours, minutes, and seconds * VHF radio (COM) with speaker and microphone * VOR receiver * Transponder (XPDR), Mode A and Mode C * 1 headset 	<ul style="list-style-type: none"> * Second VHF radio (COM) * VOR-LOC-GP receiver * Marker beacon receiver
Engine Instruments	<ul style="list-style-type: none"> * Fuel indicators * Integrated engine instrument * Annunciator panel (all lights, see 2.6) 	<ul style="list-style-type: none"> * Ammeter (included in VM 1000) * Voltmeter (included in VM 1000) 	

Minimum Operational Equipment (Serviceable)

	For Daytime VFR Flights	In Addition for Night VFR Flights	In addition for IFR Flights
Lighting		<ul style="list-style-type: none"> * Position lights * Strobe lights (anti collision lights) * Landing light * Instrument lighting * Flood light * Flashlight 	
Other Operational Minimum Equipment	<ul style="list-style-type: none"> * Stall warning system * Fuel quantity measuring device (see 7.10) * Safety belts for each occupied seat * Airplane flight manual 	<ul style="list-style-type: none"> * Pitot heating system * Alternate static valve * Essential bus 	<ul style="list-style-type: none"> * Emergency battery

NOTE

A list of approved equipment can be found in Chapter 6.

NOTE

For the upgrade of an airplane for Night VFR or IFR operation it is not sufficient to install the required equipment. The retrofit must be carried out in accordance with the requirements of the manufacturer (see Service Bulletins) and the national Airworthiness Authority. Any additional equipment (equipment which is not listed in the Equipment List in Section 6.5) must also be approved for the intended kind of operation by the national Airworthiness Authority.

2.14 FUEL

I Fuel Grade AVGAS 100LL / ~~AVGAS 100/130LL (ASTM D910)~~

I ~~AVGAS 100 / AVGAS 100/130 (ASTM D910)~~

Fuel Quantity

a) Standard Tank:

Total fuel quantity : 2 x 20.6 US gal (app. 2 x 78 liter)

Unusable fuel : 2 x 0.5 US gal (app. 2 x 2 liter)

Max. indicated fuel quantity:

up to and incl. serial no. 40.054 : 15 US gal (app. 57 liter) per tank

serial no. 40.055 & subsequent : 17 US gal (app. 64 liter) per tank

Max. permissible difference

between right and left tank : 10 US gal (app. 38 liter)

b) Long Range Tank (if installed):

Total fuel quantity	: 2 x 25.5 US gal (app. 2 x 96.5 liter)
Unusable fuel	: 2 x 0.5 US gal (app. 2 x 2 liter)
Max. indicated fuel quantity	: 16 US gal (app. 61 liter) per tank
Indicated quantity auxiliary fuel tank	: 0 to 9 US gal (app. 0 to 34 liter) per tank
Max. permissible difference between right and left tank	: 8 US gal (app. 30 liter)

CAUTION

If a fuel indicator shows 16 US gal and the aux. fuel indicator reads 0 US gal on the same side, then 19 US gal must be assumed for the calculation of the difference between right and left tank.

2.15 LIMITATION PLACARDS

All *limitation* placards are shown below. A list of *all* placards is included in the Airplane Maintenance Manual (Doc. No. 6.02.01), Chapter 11.

On the Instrument Panel:

! *If MAM 40-227 is not carried out:*

Maneuvering speed:

$v_A = 108$ KIAS (above 980 up to 1150 kg / above 2161 up to 2535 lb)

$v_A = 94$ KIAS (780 to 980 kg / 1720 to 2161 lb)

This airplane may only be operated in accordance with the Airplane Flight Manual. It can be operated in the “Normal” and “Utility” categories in non-icing conditions. Provided that national operational requirements are met and the appropriate equipment is installed, this airplane is approved for the following kinds of operation: day VFR, night VFR and IFR. All aerobatic maneuvers including spinning are prohibited.

For further operational limitations refer to the Airplane Flight Manual.

No smoking.

If MÄM 40-227 is carried out:

Maneuvering Speed:

$v_A = 111$ KIAS (above 1036 up to 1200 kg, above 2284 up to 2646 lb)

$v_A = 94$ KIAS (780 to 1036 kg, 1720 to 2284 lb)

The airplane may only be operated in accordance with the Airplane Flight Manual. It can be operated in the „Normal“ and the „Utility“ categories in non-icing conditions. Provided that national operational requirements are met and the appropriate equipment is installed, this airplane is approved for the following kinds of operation: day VFR, night VFR and IFR. All aerobatic maneuvers including spinning are prohibited.

For further operational limitations refer to the Airplane Flight Manual.

No smoking.

Next to Each of the Two Fuel Filler Necks:

a) Standard Tank:

If MÄM 40-617 is installed:

AVGAS 100LL

76 l / 20 US gal.

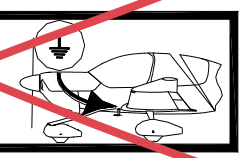

AVGAS 100LL
or see Airplane Flight Manual

Usable Fuel QTY
76 l / 20 US gal.

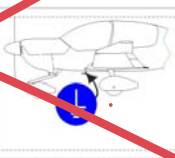

b) Long Range Tank (if installed):

If MÄM 40-617 is installed:

AVGAS 100LL

94 l / 25 US gal.

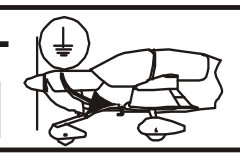

AVGAS 100LL
or see Airplane Flight Manual

Usable Fuel QTY
94 l / 25 US gal.

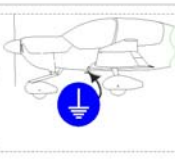

Next to the Fuel Quantity Indication:

a) *Standard Tank:*

Up to serial number 40.054:

max. indicated fuel quantity: 15 US gal

left and right tank max. 10 US gal difference

For use of max. tank capacity see AFM

Serial number 40.055 and subsequent:

max. indicated fuel quantity: 17 US gal

left and right tank max. 10 US gal difference

For use of max. tank capacity see AFM

b) *Long Range Tank (if installed):*

Fuel qty. indication: 16 + 9 US gal

max. difference LH/RH tank: 8 US gal

AUX FUEL QTY switch for LH/RH auxiliary fuel quantity

NOTE: See AFM for more information on AUX FUEL

On the Fuel Tank Selector:

a) *Standard Tank:*

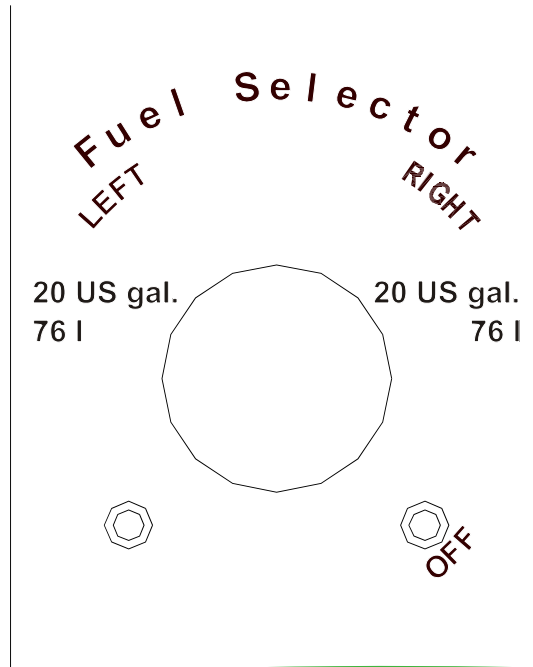

b) *Long Range Tank (if installed):*

Plane says:
24 US gal.
91 l

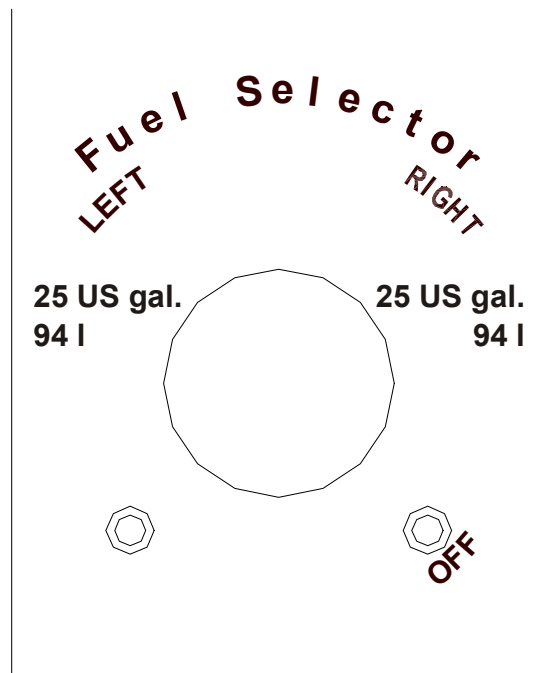

In the Cowling, on the Door for the Oil Filler Neck:

OIL 1 qt = 0.95 liters

SAE 15W50

ashless dispersant aviation
grade oil (SAE Standard J-1899)
or see AFM Chapter 2

VFR Min./Max.: 4/8 qts

IFR Min./Max.: 6/8 qts

Next to the Flap Selector Switch:

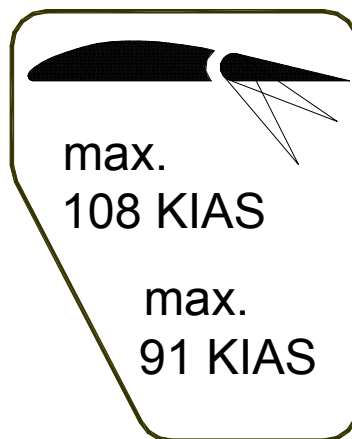

Next to the Essential Bus Switch (if installed):

Ess. Bus NOT for normal operation. See AFM.

In the Cockpit, on the Left Fuselage Sidewall:

(if alternate static valve is installed):

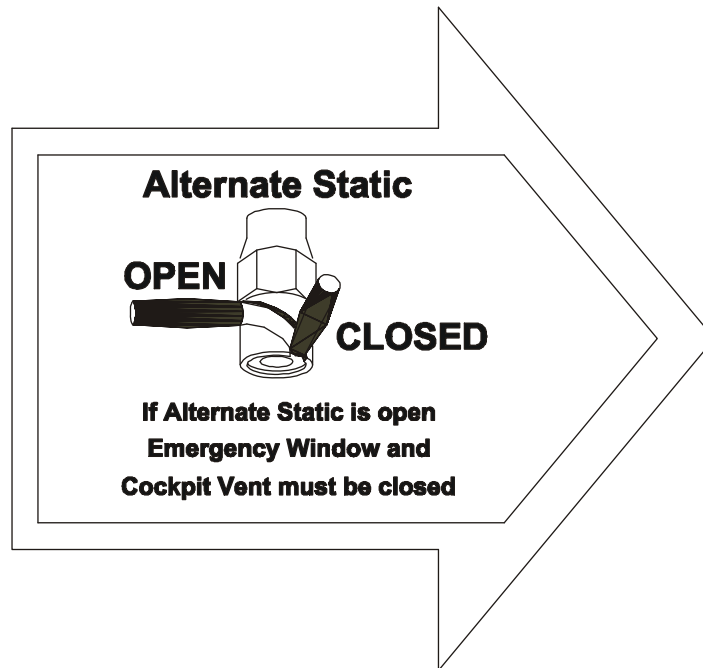

Next to the Baggage Compartment:

a) *Standard Baggage Compartment:*



b) *Extended Baggage Compartment (OÄM 40-163, if installed):*

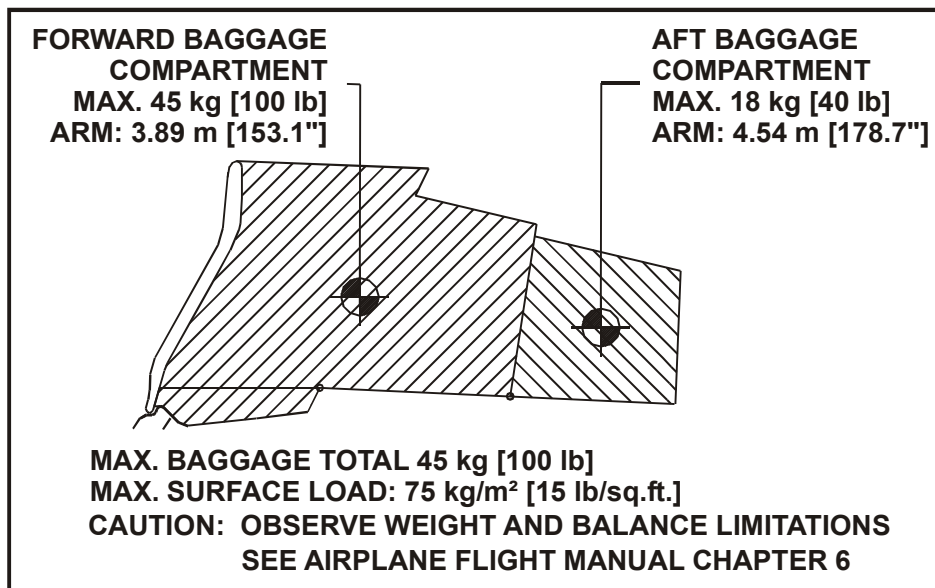

Beside the Door Locking Device (OÄM 40-081, if installed):

EMERGENCY EXIT:
The keylock must be
unlocked during flight!

Above the NAV #2 CDI (OÄM 40-206, if installed):

**NAV No. 2 not approved
for precision approaches**

2.16 OTHER LIMITATIONS

2.16.1 TEMPERATURE

- █ The airplane may only be operated when its temperature prior to operation is not less
- █ than -40 °C (-40 °F) and not higher than 54 °C (129 °F).

CAUTION

For cold weather starting of the engine refer to the latest instructions given by the engine manufacturer.

2.16.2 BATTERY CHARGE

Taking off for a Night VFR or IFR flight with an empty battery is not permitted.

The use of an external power supply for engine starting with an empty airplane battery is not permitted if the subsequent flight is intended to be an IFR flight. In this case the airplane battery must first be charged.

2.16.3 EMERGENCY SWITCH

IFR flights are not permitted when the seal on the emergency switch is broken.

2.16.4 OPERATION TIME OF ELECTRICAL EQUIPMENT

Following an alternator failure and with the essential bus (if installed) switched ON, it can be expected that the systems listed under 3.7.2 - FAILURES IN THE ELECTRICAL SYSTEM are supplied with power for half an hour. After this, electrical power is available

for the attitude gyro (artificial horizon) and flood light for another 1.5 hours when the emergency power pack (if installed) is used.

2.16.5 DOOR LOCKING DEVICE

The canopy and the passenger door must not be blocked by the door locking device during operation of the airplane.

2.16.6 ELECTRONIC EQUIPMENT

The use and switching on of electronic equipment other than that which is part of the equipment of the airplane is not permitted, as it could lead to interference with the airplane's avionics.

Examples of undesirable items of equipment are:

- Mobile telephones.
- Remote radio controls.
- Video screens employing CRTs.
- MiniDisc recorders when in the record mode.

This list is not exhaustive.

The use of laptop computers, including those with CD-ROM drives, CD and minidisc players in the replay mode, cassette players and video cameras is permitted. All this equipment however should be switched off for take-off and landing.

2.16.7 USE OF THE SUN VISORS

- The sun visors (if installed, CAM 40-327) may only be used during cruise. During all other phases of flight the sun visors must be locked in the fully upward position.

Intentionally left blank.

CHAPTER 3

EMERGENCY PROCEDURES

	Page
3.1 INTRODUCTION	3-3
3.1.1 GENERAL	3-3
3.1.2 CERTAIN AIRSPEEDS IN EMERGENCIES	3-4
3.2 ENGINE PROBLEMS	3-5
3.2.1 ENGINE PROBLEMS ON THE GROUND	3-5
3.2.2 ENGINE PROBLEMS DURING TAKE-OFF	3-6
3.2.3 ENGINE PROBLEMS IN FLIGHT	3-8
3.2.4 RESTARTING THE ENGINE WITH WINDMILLING PROPELLER	3-17
3.2.5 DEFECTIVE ENGINE CONTROLS	3-18
3.2.6 RESTARTING THE ENGINE WITH STATIONARY PROPELLER	3-20
3.3 SMOKE AND FIRE	3-22
3.3.1 SMOKE AND FIRE ON THE GROUND	3-22
3.3.2 SMOKE AND FIRE DURING TAKE-OFF	3-24
3.3.3 SMOKE AND FIRE IN FLIGHT	3-26
3.4 GLIDING	3-28
3.5 EMERGENCY LANDINGS	3-29
3.5.1 EMERGENCY LANDING WITH ENGINE OFF	3-29
3.5.2 LANDING WITH A DEFECTIVE TIRE ON THE MAIN LANDING GEAR	3-31
3.5.3 LANDING WITH DEFECTIVE BRAKES	3-32
3.6 RECOVERY FROM AN UNINTENTIONAL SPIN	3-33

3.7	OTHER EMERGENCIES	3-34
3.7.1	ICING	3-34
3.7.2	FAILURES IN THE ELECTRICAL SYSTEM	3-35
3.7.3	SUSPICION OF CARBON MONOXIDE CONTAMINATION IN THE CABIN	3-39
3.7.4	'DOOR'-WARNING LIGHT ON	3-40
3.7.5	EMERGENCY EXIT	3-41

NOTE

Procedures for uncritical system faults are given in Chapter
4B - ABNORMAL OPERATING PROCEDURES.

3.1 INTRODUCTION

3.1.1 GENERAL

This Chapter contains checklists as well as the description of recommended procedures to be followed in the event of an emergency. Engine failure or other airplane-related emergencies are most unlikely to occur if the prescribed procedures for pre-flight checks and airplane maintenance are followed.

If, nonetheless, an emergency does arise, the guidelines given here should be followed and applied in order to clear the problem.

As it is impossible to foresee all kinds of emergencies and cover them in this Airplane Flight Manual, a thorough understanding of the airplane by the pilot is, in addition to his knowledge and experience, an essential factor in the solution of any problems which may arise.

WARNING

In each emergency, control over the flight attitude and the preparation of a possible emergency landing have priority over attempts to solve the current problem ("first fly the aircraft"). Prior to the flight the pilot must consider the suitability of the terrain for an emergency landing for each phase of the flight. For a safe flight the pilot must constantly keep a safe minimum flight altitude. Solutions for various adverse scenarios should be thought over in advance. Thus it should be guaranteed that the pilot is at no time shocked by an engine failure and that he can act calmly and with determination.

3.1.2 CERTAIN AIRSPEEDS IN EMERGENCIES

Event \ Flight Mass		850 kg	1000 kg	1150 kg	1200 kg
		1874 lb	2205 lb	2535 lb	2646 lb
Engine failure after take-off (Flaps T/O)		59 KIAS	66 KIAS	72 KIAS	74 KIAS
Airspeed for best glide angle (Flaps UP)		60 KIAS	68 KIAS	73 KIAS	76 KIAS
Emergency landing with engine off	Flaps UP	60 KIAS	68 KIAS	73 KIAS	76 KIAS
	Flaps T/O	59 KIAS	66 KIAS	72 KIAS	74 KIAS
	Flaps LDG	58 KIAS	63 KIAS	71 KIAS	73 KIAS

3.2 ENGINE PROBLEMS

3.2.1 ENGINE PROBLEMS ON THE GROUND

- 1. Throttle IDLE
- 2. Brakes as required
- 3. Engine switch off, if considered necessary; otherwise establish the cause of the problem and re-establish engine performance

CAUTION

If the oil pressure is below the green sector, the engine must be switched off immediately.

WARNING

If the problem cannot be cleared, the airplane must not be flown.

END OF CHECKLIST

3.2.2 ENGINE PROBLEMS DURING TAKE-OFF

(a) Take-Off Can Still Be Aborted (Sufficient Runway Length Available)

Land Straight Ahead:

1. Throttle IDLE

On the Ground:

2. Brakes as required

CAUTION

If sufficient time is remaining, the risk of fire in the event of a collision can be reduced as follows:

- Fuel tank selector OFF
- Mixture control lever LEAN - shut engine off
- Ignition switch OFF
- Master switch (ALT/BAT) OFF

CONTINUED

█ (b) Take-Off Can No Longer Be Aborted

- █ 1. Airspeed 74 KIAS (1200 kg, 2646 lb)
72 KIAS (1150 kg, 2535 lb)
66 KIAS (1000 kg, 2205 lb)
59 KIAS (850 kg, 1874 lb)

WARNING

█ If, in the event of an engine problem occurring during take-off, the take-off can no longer be aborted and a safe height has not been reached, then a straight-ahead emergency landing should be carried out. Turning back can be fatal.

If Time Allows:

- 2. Fuel tank selector check selected tank
- 3. Electrical fuel pump check ON
- 4. Ignition switch check BOTH
- 5. Throttle check MAX PWR
- 6. RPM lever check HIGH RPM
- 7. Mixture control lever check RICH (leaner above 5000 ft)

- 8. Alternate Air OPEN

WARNING

If the problem does not clear itself immediately, and the engine is no longer producing sufficient power, then an emergency landing must be carried out.

END OF CHECKLIST

3.2.3 ENGINE PROBLEMS IN FLIGHT

(a) Engine Running Roughly

WARNING

An engine which is running very roughly can lead to the loss of the propeller. If the engine is running roughly operation should only be continued if there is no other alternative.

1. Airspeed 76 KIAS (1200 kg, 2646 lb)
73 KIAS (1150 kg, 2535 lb)
68 KIAS (1000 kg, 2205 lb)
60 KIAS (850 kg, 1874 lb)
2. Electrical fuel pump check ON
3. Fuel tank selector check selected tank
4. Engine instruments check
5. Throttle check
6. RPM lever check
7. Mixture control lever set for smooth running
8. Alternate Air OPEN
- ~~9. Ignition status light check (only if the electronic ignition control unit is installed)~~
10. Ignition switch check BOTH

CONTINUED

- 11. ~~Ignition circuit breaker (IGN) pull (only if the electronic ignition control unit is installed), if rough running is cleared by doing this, the circuit breaker should remain open.~~

- 12. Throttle/RPM/Mixture try various settings

WARNING

If the problem does not clear itself immediately, and the engine is no longer producing sufficient power, then an emergency landing should be carried out.

END OF CHECKLIST

(b) Loss of Oil Pressure

1. Check oil pressure warning light and oil pressure indicator.
2. Check oil temperature.
 - 2a. If the oil pressure indication drops below the green sector and the oil temperature is normal (oil pressure warning light does not illuminate or flash):
 - * Monitor the oil pressure warning light: it is probable that the oil pressure indication is defective.
 - * Monitor the oil and cylinder head temperatures.
 - 2b. If the oil pressure indication drops below the green sector while the oil or cylinder head temperature is rising, or
If the oil pressure warning light illuminates or flashes, or
If both of these occur together:
 - * Reduce engine power to the minimum required.
 - * Land as soon as possible.
 - * Be prepared for engine failure and emergency landing.
 - 2c. Oil pressure tending to zero combined with:
Vibration, loss of oil, possibly unusual metallic noise and smoke:
 - * A mechanical failure in the engine is apparent.
 - * Shut off engine immediately and
 - * Carry out emergency landing in accordance with 3.5.1 - EMERGENCY LANDING WITH ENGINE OFF.

END OF CHECKLIST

Page 3 - 10	Rev. 8	01-Dec-2010	Doc. # 6.01.01-E
-------------	--------	-------------	------------------

(c) High Oil Pressure

Check oil temperature.

- * If the oil temperature is normal, it is probable that the fault lies in the oil pressure indication, which should thus be ignored (the airplane should be serviced).

END OF CHECKLIST(d) High Oil Temperature

Check cylinder head and exhaust gas temperature.

- * If neither of these is high, it is probable that the fault lies in the oil temperature indication. The airplane should be serviced. A stable oil temperature indication of 26 °F (-3 °C) or 317 °F (158 °C) suggests a failure of the oil temperature sensor.
- * If the cylinder head temperature or exhaust gas temperature is also high:
 - Check oil pressure. If the oil pressure is low, proceed as in 3.2.3 (b) - LOSS OF OIL PRESSURE.
 - If the oil pressure is in the green sector:
 - Check mixture setting, enrich mixture if necessary.
 - Reduce power; if this produces no improvement, land at the nearest appropriate airfield.

END OF CHECKLIST

(e) High Cylinder Head Temperature

Cylinder head temperature in yellow sector or above:

1. Check mixture setting, enrich mixture if necessary.
2. Check oil temperature.

* If the oil temperature is also high:

- Check oil pressure. If the oil pressure is low, proceed as in 3.2.3 (b) - LOSS OF OIL PRESSURE.
- If the oil pressure is in the green sector:
 - Reduce power; if this produces no improvement, land at the nearest appropriate airfield.
 - Be prepared for possible emergency landing.

END OF CHECKLIST

(f) High RPM

RPM moves on its own into the yellow sector, or is in the red sector:

1. Check friction adjuster for throttle quadrant.
2. Check oil pressure: Following a loss of oil or oil pressure, the propeller governor sets a high RPM. In this case the RPM should be regulated using the throttle. Proceed as in 3.2.3 (b) - LOSS OF OIL PRESSURE.
3. If oil pressure is normal:
 - * Pull RPM lever back and listen for an associated drop in RPM:
 - If the indication does not change in spite of an audible drop in RPM, it is probable that the RPM indication is defective, which should thus be ignored (the airplane should be serviced).
 - If there is no audible drop in RPM, it is probable that the governor system is defective. In this case the RPM should be regulated using the throttle.

END OF CHECKLIST

(g) Loss of RPM

1. Electrical fuel pump check ON
2. Fuel tank selector check
3. Friction adjuster for throttle quadrant check sufficiently tight
4. RPM lever HIGH RPM

* Listen for rise in RPM.

- If there is no audible rise in RPM, it is probable that the governor system is defective. In this case the RPM can be regulated within certain limits using the throttle.
 - Land at the nearest appropriate airfield.
 - Be prepared for possible emergency landing.
- If the indication does not change in spite of an audible rise in RPM, it is probable that the RPM indication is defective, which should thus be ignored (the airplane should be serviced).

END OF CHECKLIST

(h) High Fuel Flow

Fuel flow in the red sector:

1. Electrical fuel pump ON
2. Fuel pressure check after 10 - 15 sec:
 - * If the fuel pressure is low, refer to 3.2.3 (i) - LOW FUEL PRESSURE WITH THE ELECTRICAL FUEL PUMP SET TO ON.
 - * If the fuel pressure is in the green sector, or the fuel pressure warning light is not illuminated, the likely cause is a defective fuel flow indication, which should thus be ignored (the airplane should be serviced). Fuel flow data should be taken from the engine performance table in Chapter 5.
3. Check fuel quantity. A rapid reduction in fuel quantity confirms a high fuel flow.

END OF CHECKLIST

(i) Low Fuel Pressure with the Electrical Fuel Pump Set to ON

Fuel pressure warning light illuminates, or fuel pressure indication below the green sector:

1. Fuel flow check:

- * If the fuel flow is high, there is possibly a leak (between the injection system and the injectors). Land on the nearest suitable airfield.
- * If the fuel flow is in the green sector and the engine is running smoothly, the likely cause is a defective fuel pressure indication, which should thus be ignored (the airplane should be serviced).

Monitor engine for power loss and rough operation that could indicate fuel starvation. If the engine is no longer producing sufficient power, then an emergency landing should be carried out.

END OF CHECKLIST

3.2.4 RESTARTING THE ENGINE WITH WINDMILLING PROPELLER

NOTE

Restarting the engine is possible at all airspeeds above 70 KIAS up to v_{NE} and up to the maximum demonstrated operating altitude.

NOTE

As long as an airspeed of at least 65 KIAS is maintained, and there is no major engine failure, the propeller will continue to windmill.

1. Airspeed 80 KIAS
2. Fuel tank selector fullest tank
3. Ignition switch check BOTH
4. Mixture control lever check appropriate position
5. Electrical fuel pump check ON
6. Alternate air OPEN

If Engine Does Not Start:

7. Mixture control lever LEAN
8. Mixture control lever push forward slowly until engine starts

NOTE

If it is not possible to start the engine:

- Adopt glide configuration as in 3.4 - GLIDING.
- Carry out emergency landing as in 3.5.1 - EMERGENCY LANDING WITH ENGINE OFF.

END OF CHECKLIST

3.2.5 DEFECTIVE ENGINE CONTROLS

Defective Mixture Control Cable

(a) Flight and Landing:

1. Maintain altitude to the nearest airfield.
2. During descent, test the reaction of the engine to a higher power setting. A lean mixture can lead to engine roughness and a loss of power. The landing approach must be planned accordingly.

WARNING

Go-around may become impossible with the remaining power.

(b) Engine Shut-Down:

1. Parking brake set
2. Engine instruments check
3. Avionics master switch OFF
4. All electrical equipment OFF
5. Throttle IDLE
6. Ignition switch OFF
7. Master switch (ALT/BAT) OFF

END OF CHECKLIST

Defective Throttle Control Cable*(a) Sufficient Engine Power Available to Continue Flight:*

1. Approach nearest airfield, control engine power with RPM lever.
2. Perform landing with shut-down engine.

(b) No Sufficient Engine Power Available to Continue Flight:

1. Carry out emergency landing as in 3.5.1 - EMERGENCY LANDING WITH ENGINE OFF.

END OF CHECKLISTDefective RPM Lever Control Cable*(a) Sufficient Engine Power Available to Continue Flight:*

1. Approach nearest airfield, control engine power with throttle.
2. Perform normal landing.

WARNING

Go-around may become impossible with the remaining power.

(b) No Sufficient Engine Power Available to Continue Flight:

1. Carry out emergency landing as in 3.5.1 - EMERGENCY LANDING WITH ENGINE OFF.

END OF CHECKLIST

3.2.6 RESTARTING THE ENGINE WITH STATIONARY PROPELLER

NOTE

Restarting the engine is possible at all airspeeds above 80 KIAS up to v_{NE} and up to the maximum demonstrated operating altitude.

1. Airspeed 80 KIAS
2. Electrical equipment OFF
3. Avionics master switch OFF
4. Master switch (BAT) check ON
5. Mixture control lever check
6. Fuel tank selector check
7. Electrical fuel pump check ON
8. Alternate air OPEN
9. Ignition switch START

NOTE

By increasing the airspeed above approximately 130 KIAS, the propeller will begin to rotate and the engine can thus be started. For this, the Ignition switch should be set at BOTH (see 3.2.4 - RESTARTING THE ENGINE WITH WINDMILLING PROPELLER). An altitude loss of at least 1000 ft (300 meter) must be allowed for.

if it is not possible to start the engine:

- Adopt glide configuration as in 3.4 - GLIDING
- Carry out emergency landing as in 3.5.1 - EMERGENCY LANDING WITH ENGINE OFF.

CONTINUED

CAUTION

Engine restart following an engine fire should only be attempted if it is unlikely that a safe emergency landing can be made. It must be expected that engine restart is impossible after an engine fire.

END OF CHECKLIST

3.3 SMOKE AND FIRE

3.3.1 SMOKE AND FIRE ON THE GROUND

(a) Engine Fire When Starting on the Ground

1. Fuel tank selector OFF
2. Cabin heat OFF
3. Brakes apply

After Standstill:

4. Throttle MAX PWR
5. Master switch (ALT/BAT) OFF

When the Engine Has Stopped:

6. Ignition switch OFF
7. Canopy open
8. Airplane evacuate immediately

END OF CHECKLIST

(b) Electrical Fire with Smoke on the Ground

- 1. Master switch (ALT/BAT) OFF

If the Engine is Running:

- 2. Throttle IDLE
- 3. Mixture control lever LEAN - shut off engine

When the Engine Has Stopped:

- 4. Ignition switch OFF
- 5. Canopy open
- 6. Airplane evacuate immediately

END OF CHECKLIST

3.3.2 SMOKE AND FIRE DURING TAKE-OFF

(a) If Take-Off Can Still Be Aborted

1. Throttle IDLE
2. Cabin heat OFF
3. Brakes apply - bring the airplane to a stop
4. After stopping proceed as in 3.3.1 - SMOKE AND FIRE ON THE GROUND

END OF CHECKLIST

(b) If Take-Off Cannot Be Aborted

1. Cabin heat OFF
2. If possible, fly along a short-cut traffic circuit and land on the airfield.

WARNING

If, in the event of an engine problem occurring during take-off, the take-off can no longer be aborted and a safe height has not been reached, then a straight-ahead emergency landing should be carried out. Turning back can be fatal.

3. Airspeed 74 KIAS (1200 kg, 2646 lb)
72 KIAS (1150 kg, 2235 lb)
66 KIAS (1000 kg, 2205 lb)
59 KIAS (850 kg, 1874 lb)

CONTINUED

After Climbing to a Height From Which the Selected Landing Area Can Be Reached Safely:

- 4. Fuel tank selector OFF
- 5. Electrical fuel pump OFF
- 6. Cabin heat OFF
- 7. Master switch (ALT/BAT) OFF
- 8. Emergency window(s) open if required
- 9. Carry out emergency landing with engine off. Allow for increased landing distance due to the flap position.

CAUTION

In case of extreme smoke development, the front canopy may be unlatched during flight. This allows it to partially open, in order to improve ventilation. The canopy will remain open in this position. Flight characteristics will not be affected significantly.

END OF CHECKLIST

3.3.3 SMOKE AND FIRE IN FLIGHT

CAUTION

In the event of smoke or fire, prepare to land the airplane without delay while completing fire suppression and/or smoke evacuation procedures. If it cannot be visually verified that the fire has been completely extinguished, whether the smoke has cleared or not, land immediately at the nearest suitable airfield or landing site.

(a) Engine Fire in Flight

1. Cabin heat OFF
2. Select appropriate emergency landing field.

When it Seems Certain that the Landing Field Will Be Reached:

3. Fuel tank selector OFF
4. Throttle MAX PWR
5. Electrical fuel pump OFF
6. Master switch (ALT/BAT) ON
7. Emergency window(s) open if required
8. Carry out emergency landing with engine off.

CAUTION

In case of extreme smoke development, the front canopy may be unlatched during flight. This allows it to partially open, in order to improve ventilation. The canopy will remain open in this position. Flight characteristics will not be affected significantly.

END OF CHECKLIST

(b) Electrical Fire with Smoke in Flight

- 1. Emergency switch ON if installed
- 2. Master switch (ALT/BAT) OFF
- 3. Cabin heat OFF
- 4. Emergency window(s) open if required
- 5. Land at an appropriate airfield as soon as possible.

CAUTION

Switching OFF the Master switch (ALT/BAT) will lead to total failure of all electronic and electric equipment. Also affected from this are - if installed - the attitude gyro (artificial horizon) and the directional gyro.

However, by switching the Emergency switch ON (only installed in the IFR model), the emergency battery will supply power to the attitude gyro (artificial horizon) and the flood light.

CAUTION

In case of extreme smoke development, the front canopy may be unlatched during flight. This allows it to partially open, in order to improve ventilation. The canopy will remain open in this position. Flight characteristics will not be affected significantly.

END OF CHECKLIST

3.4 GLIDING

1. Flaps UP
2. Airspeed 76 KIAS (1200 kg, 2646 lb)
73 KIAS (1150 kg, 2535 lb)
68 KIAS (1000 kg, 2205 lb)
60 KIAS (850 kg, 1874 lb)

NOTE

The glide ratio is 8.8; i.e., for every 1000 ft (305 meter) of altitude loss the maximum horizontal distance traveled in still air is 1.45 NM (2.68 km). During this the propeller will continue to windmill.

With a stationary propeller the glide ratio is 10.3; this corresponds to a maximum horizontal distance of 1.70 NM (3.14 km) for every 1000 ft altitude. In consideration of a safe airspeed however, this configuration may not be attainable.

END OF CHECKLIST

3.5 EMERGENCY LANDINGS

3.5.1 EMERGENCY LANDING WITH ENGINE OFF

CAUTION

For emergency landing the adjustable backrests (if installed) must be fixed in the upright position.

- ~~1. Adjustable backrests (if installed) adjust to the upright position described by a placard on the roll-over bar and verify proper fixation.~~
- 2. Select suitable landing area. If no level landing area is available, a landing on an upward slope should be sought.
- 3. Consider wind.
- 4. Approach: If possible, fly along a short-cut rectangular circuit. On the downwind leg of the circuit the landing area should be inspected for obstacles from a suitable height. The degree of offset at each part of the circuit will allow the wind speed and direction to be assessed.
- 5. Airspeed 76 KIAS (1200 kg, 2646 lb)
73 KIAS (1150 kg, 2535 lb)
68 KIAS (1000 kg, 2205 lb)
60 KIAS (850 kg, 1874 lb)
- 6. If time allows advise ATC
- 7. Fuel tank selector OFF

CONTINUED

When It Is Certain That the Landing Field Will Be Reached:

- 8. Flaps LDG
- 9. Safety harnesses tighten

CAUTION

If sufficient time is remaining, the risk of fire in the event of a collision with obstacles can be reduced as follows:

- Ignition switch OFF
- Master switch (ALT/BAT) OFF

- 10. Touchdown with the lowest possible airspeed

END OF CHECKLIST

3.5.2 LANDING WITH A DEFECTIVE TIRE ON THE MAIN LANDING GEAR**CAUTION**

A defective (e.g. burst) tire is not usually easy to detect. The damage normally occurs during take-off or landing, and is hardly noticeable during fast taxiing. It is only during the roll-out after landing or at lower taxiing speeds that a tendency to swerve occurs. Rapid and determined action is then required.

1. Advise ATC.
2. Land the airplane at the edge of the runway that is located on the side of the intact tire, so that changes in direction which must be expected during roll-out due to the braking action of the defective tire can be corrected on the runway.
3. Land with one wing low. The wing on the side of the intact tire should be held low.
4. Direction should be maintained using the rudder. This should be supported by use of the brake. It is possible that the brake must be applied strongly - if necessary to the point where the wheel locks. The wide track of the landing gear will prevent the airplane from tipping over a wide speed range. There is no pronounced tendency to tip even when skidding.

END OF CHECKLIST

3.5.3 LANDING WITH DEFECTIVE BRAKES

In general, a landing on grass is recommended in order to reduce the landing run by virtue of the greater rolling resistance.

CAUTION

If sufficient time is remaining, the risk of fire in the event of a collision can be reduced as follows:

- Fuel tank selector OFF
- Mixture control lever LEAN - shut off engine
- Ignition switch OFF
- Master switch (ALT/BAT) OFF

END OF CHECKLIST

3.6 RECOVERY FROM AN UNINTENTIONAL SPIN

CAUTION

Steps 1 to 4 must be carried out **immediately** and **simultaneously**.

- 1. Throttle IDLE
- 2. Rudder full deflection against
direction of spin
- 3. Elevator (control stick) fully forward
- 4. Ailerons neutral
- 5. Flaps UP

When Rotation Has Stopped:

- 6. Rudder neutral
- 7. Elevator (control stick) pull carefully
- 8. Return the airplane from a descending into a normal flight attitude. In so doing do not exceed the 'never exceed speed', V_{NE} .

END OF CHECKLIST

3.7 OTHER EMERGENCIES

3.7.1 ICING

Unintentional Flight Into Icing Conditions

1. Leave the icing area (by changing altitude or turning back, in order to reach zones with a higher ambient temperature).
2. Pitot heating ON
3. Cabin heat ON
4. Air distributor lever ▲ (up)
5. RPM increase, in order to prevent ice build-up on the propeller blades
6. Alternate air OPEN
7. Emergency window(s) open if required

CAUTION

Ice build-up increases the stalling speed. If required for safety reasons, engine speeds up to 2700 RPM are admissible without time limit.

8. ATC advise if an emergency is expected

CAUTION

When the Pitot heating fails, and the alternate static valve is installed:

- Alternate static valve OPEN
- Emergency window(s) close

END OF CHECKLIST

3.7.2 FAILURES IN THE ELECTRICAL SYSTEM**(a) Complete Failure of the Electrical System**

Due to the strong mechanical design as well as due to the required check of the system during scheduled inspections, a total failure of the electrical system is extremely unlikely. If, nevertheless, a total failure should occur, all circuit breakers should be checked, pulled and re-set. If this does not help:

- Set Emergency switch to ON (if installed).
- When necessary, use the flood light for lighting the instruments as well as levers and switches, etc.
- Set power based on lever positions and engine noise.
- Prepare landing with flaps in the given position.
- Land on the nearest appropriate airfield.

END OF CHECKLIST

(b) Alternator Failure

An alternator failure is indicated by an illuminated or flashing alternator warning light (ALT or ALTERNATOR) on the annunciator panel and a flashing ammeter on the Vision Microsystems VM 1000 engine instrument.

(i) Alternator Failure During Flight

1. Circuit breakers check; if all are OK, proceed with step 2
2. Electrical equipment switch OFF all equipment which is not needed
3. Voltmeter check regularly

CAUTION

Those items of equipment which are not needed for the safe operation and secure landing of the airplane can be switched off with the Essential Bus switch (if installed). When the essential bus is switched ON, only the following items of equipment are supplied with power:

- NAV/COM 1.
- Transponder (XPDR).
- Flood light.
- Attitude gyro (artificial horizon).
- VM 1000 engine instrument.
- Annunciator panel.
- GPS (if installed).
- Landing light.
- Pitot heating system.
- Flaps.

CONTINUED

These items of equipment can be supplied with power by the battery for at least 30 minutes. Economical use, in particular of the Pitot heating, and switching off equipment that is not needed extends the time during which the other equipment remains available. During the 30 minutes period, the airplane must be landed at a suitable airfield.

For cases in which the battery capacity is not sufficient to reach a suitable airfield, an emergency battery is installed in the IFR model, serving as an additional back-up system for the attitude gyro (artificial horizon) and flood light. This battery is switched on with the Emergency switch. It lasts for 1 hour and 30 minutes when the flood light is switched on.

■ *(ii) Alternator Failure on the Ground*

■ **NOTE**

■ An alternator failure may also be indicted on ground with the engine running on IDLE.

- 1. Engine speed 1200 RPM
- 2. Electrical equipment OFF
- 3. Ammeter check

■ If the caution light does not extinguish, and the ammeter flashes and reads zero:

- - Terminate flight preparation.

END OF CHECKLIST

(c) Starter Malfunction

If the starter does not disengage from the engine after starting (starter warning light (START) on the annunciator panel remains illuminated or flashing after the engine has started):

1. Throttle IDLE
2. Mixture control lever LEAN - shut off engine
3. Ignition switch OFF
4. Master switch (ALT/BAT) OFF

Terminate flight preparation!

END OF CHECKLIST

(d) Overvoltage

If a voltage in the upper red sector (above 32 Volts) is indicated:

1. Essential bus ON, if installed
2. Master switch (ALT) OFF

WARNING

Leave Master switch (BAT) ON!

3. Equipment that is not needed,
in particular Pitot heating OFF
4. Land on the nearest appropriate airfield.

END OF CHECKLIST

3.7.3 SUSPICION OF CARBON MONOXIDE CONTAMINATION IN THE CABIN

Carbon monoxide (CO) is a gas which is developed during the combustion process. It is poisonous and without smell. Since it occurs however usually together with fuel gases, it can be detected. Increased concentration of carbon monoxide in closed spaces can be fatal. The occurrence of CO in the cabin is possible only due to a defect. If a smell similar to exhaust gases is noticed in the cabin, the measures in the checklist below should be taken:

~~The DA 40 may be equipped with a CO detector (optional equipment, OÄM 40-253). If the visual alert annunciator illuminates in flight, press the TEST/RESET button. If the alert continues with the remote light staying ON or a smell similar to exhaust gases is noticed in the cabin, the following measures should be taken:~~

1. Cabin heat OFF
2. Ventilation open
3. Emergency window(s) open
4. Forward canopy open

CAUTION

In case of suspicion of carbon monoxide contamination in the cabin, the front canopy may be unlatched during flight. This allows it to partially open, in order to improve ventilation. The canopy will remain open in this position. Flight characteristics will not be affected significantly.

NOTE

~~The presence of carbon monoxide is indicated by a visual alarm if OÄM 40-253 is carried out.~~

END OF CHECKLIST

3.7.4 'DOOR'-WARNING LIGHT ON

- 1. Airspeed reduce immediately
- 2. Canopy check visually if closed
- 3. Rear passenger door check visually if closed

Canopy Unlocked

- 4. Airspeed below 140 KIAS
- 5. Land at the next suitable airfield.

Rear Door Unlocked

- 4. Airspeed below 140 KIAS
- 5. Land at the next suitable airfield.

WARNING

Do not try to lock the rear door in flight. The safety latch may disengage and the door opens. Usually this results in a separation of the door from the airplane.

NOTE

If the rear door has been lost the airplane can be safely flown to the next suitable airfield.

END OF CHECKLIST

3.7.5 EMERGENCY EXIT

In case of a roll-over of the airplane on ground, it can be evacuated through the rear door. For this purpose release the front hinge of the rear door. The function is displayed on a placard next to the hinge.

END OF CHECKLIST

Intentionally left blank.

CHAPTER 4A

NORMAL OPERATING PROCEDURES

	Page
4A.1 INTRODUCTION	4A-2
4A.2 AIRSPEEDS FOR NORMAL OPERATING PROCEDURES	4A-2
4A.3 CHECKLISTS FOR NORMAL OPERATING PROCEDURES ...	4A-3
4A.3.1 PRE-FLIGHT INSPECTION	4A-3
4A.3.2 BEFORE STARTING ENGINE	4A-11
4A.3.3 STARTING ENGINE	4A-13
4A.3.4 BEFORE TAXIING	4A-19
4A.3.5 TAXIING	4A-20
4A.3.6 BEFORE TAKE-OFF	4A-22
4A.3.7 TAKE-OFF	4A-25
4A.3.8 CLIMB	4A-27
4A.3.9 CRUISE	4A-29
4A.3.10 MIXTURE ADJUSTMENT	4A-31
4A.3.11 DESCENT	4A-33
4A.3.12 LANDING APPROACH	4A-34
4A.3.13 GO-AROUND	4A-36
4A.3.14 AFTER LANDING	4A-37
4A.3.15 ENGINE SHUT-DOWN	4A-38
4A.3.16 POST-FLIGHT INSPECTION	4A-39
4A.3.17 FLIGHT IN RAIN	4A-40
4A.3.18 REFUELING	4A-40
4A.3.19 FLIGHT AT HIGH ALTITUDE	4A-40

4A.1 INTRODUCTION

Chapter 4A contains checklists and describes extended procedures for the normal operation of the airplane.

4A.2 AIRSPEEDS FOR NORMAL OPERATING PROCEDURES

Event	Flight Mass	850 kg	1000 kg	1150 kg	1200 kg
		1874 lb	2205 lb	2535 lb	2646 lb
Airspeed for take-off climb (best rate-of-climb speed v_Y) (Flaps T/O)		54 KIAS	60 KIAS	66 KIAS	67 KIAS
Airspeed for cruise climb (Flaps UP)		60 KIAS	68 KIAS	73 KIAS	76 KIAS
Approach speed for normal landing (Flaps LDG)		58 KIAS	63 KIAS	71 KIAS	73 KIAS
Minimum speed during touch & go (Flaps T/O)		54 KIAS	60 KIAS	66 KIAS	67 KIAS

4A.3 CHECKLISTS FOR NORMAL OPERATING PROCEDURES

4A.3.1 PRE-FLIGHT INSPECTION

I. Cabin Check

- a) MET, NAV, mass & CG flight planning completed
- b) Airplane documents complete and up-to-date
- c) Ignition key pulled out
- d) Front canopy and rear door clean, undamaged, check locking mechanism function

- e) All electrical equipment OFF
- f) Circuit breakers set in (if one has been pulled, check reason)

- g) Engine control levers check condition, freedom of movement and full travel of throttle, RPM and mixture levers

- h) Throttle IDLE
- i) Mixture control lever LEAN
- j) RPM lever HIGH RPM
- k) Master switch (BAT) ON
- l) Annunciator panel check function (see 7.11)
- m) Fuel quantity check

CONTINUED

NOTE

Standard Tank:

Depending on the type of fuel probes installed, the indicator can read a maximum of 15 US gal or 17 US gal (refer to Section 7.10 for details). When the fuel quantity indicator reads the maximum amount of fuel detectable, the correct fuel quantity must be determined with the fuel quantity measuring device. If this measurement is not carried out, the fuel quantity available for flight planning is the indicated amount.

Long Range Tank:

At an indication of 16 US gal the quantity of auxiliary fuel can be determined by switching the AUX FUEL QTY switch to the respective position (LH or RH). The auxiliary fuel quantity is added to the 16 US gal.

An auxiliary fuel quantity of less than 3 US gal cannot be indicated by the system. In this case the quantity must be determined by means of the fuel quantity measuring device (see Section 7.10 - FUEL SYSTEM).

CAUTION

Long Range Tank:

The correct indication of the fuel quantity takes 2 minutes after actuation of the switch.

CONTINUED

- n) Position lights, strobe lights (ACLs) check
- o) Master switch (BAT) OFF
- p) Check for loose items complete
- q) Flight controls and trim free to move and correct
- r) Baggage stowed and secure
- ~~s) Emergency axe (if OÄM 40-326 installed) stowed and secure~~

END OF CHECKLIST

II. Walk-around check, visual inspection

CAUTION

A visual inspection means: examination for damage, cracks, delamination, excessive play, load transmission, correct attachment and general condition. In addition control surfaces should be checked for freedom of movement.

CAUTION

In low ambient temperatures the airplane must be completely cleared of ice, snow and similar accumulations. For approved de-icing fluids refer to Section 8.6 - DE-ICING ON THE GROUND.

CAUTION

Prior to flight, remove such items as control surfaces gust lock, Pitot cover, tow bar, etc.

CONTINUED

Doc. # 6.01.01-E	Rev. 8	01-Dec-2010	Page 4A - 5
------------------	--------	-------------	-------------

1. *Left Main Landing Gear:*

- a) Landing gear strut visual inspection
- b) Strut fairing (if installed) visual inspection
- c) Wheel fairing visual inspection
- d) Tire inflation pressure (2.5 bar/36 PSI) check
- e) Wear, tread depth of tire check
- f) Tire, wheel, brake visual inspection
- g) Brake line connection check for leaks
- h) Slip marks visual inspection
- i) Chocks remove

2. *Left Wing:*

- a) Entire wing surface visual inspection
- b) Step visual inspection
- c) Air intake on lower surface visual inspection
- d) Openings on lower surface check for traces of fuel (if tank is full, fuel may spill over through the tank vent)

- e) Tank drain drain off a small quantity, check for water and sediment

- f) Stall warning check (suck on opening)
- g) Tank filler visual inspection, fuel quantity must agree with indicator

- h) Tank air outlet in lower surface visual inspection

CONTINUED

- i) 2 stall strips on wing visual inspection
- j) Pitot probe clean, orifices open
- k) Landing/taxi light visual inspection
- l) Wing tip visual inspection
- m) Position light, strobe light (ACL) visual inspection
- n) Mooring check, clear
- o) Aileron and linkage visual inspection
- p) Aileron hinges and safety pin visual inspection
- q) Foreign objects in aileron paddle visual inspection
- r) Flap and linkage visual inspection
- s) Flap hinges and safety pin visual inspection

3. *Fuselage, Left Side:*

- a) Canopy, left side visual inspection
- b) Rear cabin door & window visual inspection
- c) Fuselage skin visual inspection
- d) Antennas visual inspection
- e) Autopilot static source (if OÄM 40-267

 installed) check for blockage

4. *Empennage:*

- a) Stabilizers and control surfaces visual inspection
- b) Hinges visual inspection
- c) Elevator trim tab visual inspection, check
locking wire
- d) Rudder trim tab visual inspection
- e) Mooring on fin check, clear
- f) Tail skid and lower fin visual inspection
- g) Towing assembly, if fitted visual inspection

CONTINUED

5. *Fuselage, Right Side:*

- a) Fuselage skin visual inspection
- b) Window visual inspection
- c) Canopy, right side visual inspection
- d) Autopilot static source (if OÄM 40-267
installed) check for blockage

6. *Right Wing:*

- a) Flap and linkage visual inspection
- b) Flap hinges and safety pin visual inspection
- c) Aileron and linkage visual inspection
- d) Aileron hinges and safety pin visual inspection
- e) Foreign objects in aileron paddle visual inspection
- f) Wing tip visual inspection
- g) Position light, strobe light (ACL) visual inspection
- h) Mooring check, clear
- i) Entire wing surface visual inspection
- j) 2 stall strips on wing visual inspection
- k) Tank air outlet in lower surface visual inspection
- l) Tank filler visual check, fuel quantity
must agree with indicator
- m) Openings on lower surface check for traces of fuel (if
tank is full, fuel may spill
over through the tank vent)
- n) Tank drain drain off a small quantity,
check for water and
sediment
- o) Step visual inspection

CONTINUED

7. Right Main Landing Gear:

- a) Landing gear strut visual inspection
- b) Strut fairing (if installed) visual inspection
- c) Wheel fairing visual inspection
- d) Tire inflation pressure (2.5 bar/36 PSI) check
- e) Wear, tread depth of tires check
- f) Tire, wheel, brake visual inspection
- g) Brake line connection check for leaks
- h) Slip marks visual inspection
- i) Chocks remove

8. Front Fuselage:

- a) Oil level check dipstick,
min. 4 qts for VFR operation
min. 6 qts for IFR operation
- b) Cowling visual inspection
- c) 3 air intakes clear
- d) Propeller visual inspection; blade
shake: max. 3 mm (1/8 in);
angular play of blade:
max. 2°

WARNING

Never move the propeller by hand while the ignition is switched on, as it may result in serious personal injury.

- e) Spinner including attachment screws visual inspection

CONTINUED

- f) Nose landing gear visual inspection
- g) Tire and wheel visual inspection
- h) Slip marks visual inspection
- i) Nose landing gear strut fairing (if installed) . . visual inspection
- j) Nose landing gear tie-down (if installed) check, clear
- k) Wear, tread depth of tire check
- l) Wheel fairing visual inspection
- m) Tow bar removed
- n) Tire inflation pressure (2.0 bar/29 PSI) check
- o) Chocks remove
- p) Exhaust visual inspection
- q) Forward cabin air inlets (if installed) clear
- r) Winter baffle for fresh air inlet (if installed) . . visual inspection

WARNING

The exhaust can cause burns when it is hot.

Underside:

- s) Antennas (if fitted) visual inspection
- t) Gascolator drain off a small quantity of
fuel, check for water and
sediment
- u) Venting pipes check for blockage
- v) Fuselage underside check for excessive
contamination particularly by
oil, fuel, and other fluids

END OF CHECKLIST

4A.3.2 BEFORE STARTING ENGINE

CAUTION

For take-off the adjustable backrests (if installed) must be fixed in the upright position.

NOTE

The pilot must ensure that a passenger sitting on a front seat is instructed in the operation of the adjustable backrest (if installed).

- 1. Pre-flight inspection complete
- 2. Rudder pedals adjusted
- 3. Passengers instructed
- ~~4. Adjustable backrests (if installed) adjust to the upright position described by a placard on the roll over bar and verify proper fixation.~~
- 5. Safety harnesses all on and fastened
- 6. Baggage check, secured
- 7. Rear door closed and locked
- 8. Door lock (if installed) unblocked, key removed

CAUTION

When operating the canopy, ensure that there are no obstructions between the canopy and the mating frame, for example seat belts, clothing, etc. When operating the locking handle do NOT apply undue force.

A slight downward pressure on the canopy may be required to ease handle operation.

CONTINUED

- 9. Front canopy Position 1 or 2 (“Cooling Gap”)
- 10. Canopy lock (if installed) unblocked, key removed
- 11. Parking brake set
- 12. Flight controls free movement
- 13. Trim wheel T/O
- 14. Throttle IDLE
- 15. RPM lever HIGH RPM
- 16. Mixture control lever LEAN
- 17. Friction device, throttle quadrant adjusted
- 18. Alternate air CLOSED
- 19. Alternate static valve CLOSED, if installed
- 20. Avionics Master switch OFF
- 21. Essential Bus switch OFF, if installed

CAUTION

When the essential bus is switched ON, the battery will not be charged unless the essential tie relay bypass (OÄM 40-126) is installed.

- 22. Master switch (BAT) ON
- 23. Annunciator panel test (see Section 7.11)
- 24. Fuel tank selector on full tank

WARNING

Never move the propeller by hand while the ignition is switched on, as it may result in serious personal injury.

Never try to start the engine by hand.

END OF CHECKLIST

4A.3.3 STARTING ENGINE

(a) Cold Engine

1. Strobe light (ACL) ON
2. Electrical fuel pump ON, note pump noise
(= functional check of pump)
3. Throttle 3 cm (1.2 in) forward from
IDLE (measured from rear of
slot)
4. Mixture control lever RICH for 3 - 5 sec, then
LEAN
5. Throttle 1 cm (0.4 in) forward from
IDLE (measured from rear of
slot)

WARNING

Before starting the engine the pilot must ensure that the propeller area is free, and no persons can be endangered.

CAUTION

Do not overheat the starter motor. Do not operate the starter motor for more than 10 seconds. After operating the starter motor, let it cool off for 20 seconds. After 6 attempts to start the engine, let the starter cool off for half an hour.

CONTINUED

CAUTION

The use of an external pre-heater and external power source is recommended whenever possible, in particular at ambient temperatures below 0 °C (32 °F), to reduce wear and abuse to the engine and electrical system. Refer to Section 4B.8 - STARTING THE ENGINE WITH EXTERNAL POWER. Pre-heat will thaw the oil trapped in the oil cooler, which can be congealed in extremely cold temperatures. After a warm-up period of approximately 2 to 5 minutes (depending on the ambient temperature) at 1500 RPM, the engine is ready for take-off if it accelerates smoothly and the oil pressure is normal and steady.

- 6. Ignition switch START

When Engine Fires:

- 7. Mixture control lever rapidly move to RICH
- 8. Oil pressure green sector within 15 sec
- 9. Electrical fuel pump OFF

WARNING

If the oil pressure has not moved into the green sector within 15 seconds after starting, SWITCH OFF ENGINE and investigate problem.

- 10. Master switch (ALT) ON
- 11. Ammeter check
- 12. Fuel pressure check (14 PSI to 35 PSI)
- 13. Annunciator panel check

END OF CHECKLIST

(b) Warm Engine

- 1. Strobe light (ACL) ON
- 2. Electrical fuel pump ON, note pump noise and fuel pressure increase
- 3. Throttle 3 cm (1.2 in) forward from IDLE (measured from rear of slot)
- 4. Mixture control lever RICH for 1 - 3 sec, then LEAN

WARNING

Before starting the engine the pilot must ensure that the propeller area is free and no persons can be endangered.

CAUTION

Do not overheat the starter motor. Do not operate the starter motor for more than 10 seconds. After operating the starter motor, let it cool off for 20 seconds. After 6 attempts to start the engine, let the starter cool off for half an hour.

- 5. Ignition switch START

CONTINUED

When Engine Fires:

6. Mixture control lever rapidly move to RICH
7. Oil pressure green sector within 15 sec

WARNING

If the oil pressure has not moved into the green sector within 15 seconds after starting, SWITCH OFF ENGINE and investigate problem.

8. Electrical fuel pump OFF
9. Master switch (ALT) ON
10. Ammeter check
11. Fuel pressure check (14 PSI to 35 PSI)
12. Annunciator panel check

END OF CHECKLIST

(c) Engine Will Not Start After Injection (“Flooded Engine”)

- 1. Strobe light (ACL) ON
- 2. Electrical fuel pump OFF
- 3. Mixture control lever LEAN, fully aft
- 4. Throttle at mid position

WARNING

Before starting the engine the pilot must ensure that the propeller area is free and no persons can be endangered.

CAUTION

Do not overheat the starter motor. Do not operate the starter motor for more than 10 seconds. After operating the starter motor, let it cool off for 20 seconds. After 6 attempts to start the engine, let the starter cool off for half an hour.

- 5. Ignition switch START
- 6. Throttle pull back towards IDLE
when engine fires

CONTINUED

When Engine Fires:

7. Mixture control lever rapidly move to RICH
8. Oil pressure green sector within 15 sec

WARNING

If the oil pressure has not moved into the green sector within 15 seconds after starting, SWITCH OFF ENGINE and investigate problem.

9. Master switch (ALT) ON
10. Ammeter check
11. Fuel pressure check (14 PSI to 35 PSI)
12. Annunciator panel check

END OF CHECKLIST

4A.3.4 BEFORE TAXIING

- 1. Avionics Master switch ON
- 2. Electrical equipment ON as required
- 3. Flaps UP - T/O - LDG - T/O
(indicator and visual check)
- 4. Flight instruments and avionics set, test function, as
required
- 5. Flood light ON, test function, as
required
- 6. Ammeter check, if required increase
RPM
- 7. Fuel tank selector change tanks, confirm that
engine also runs on other
tank (at least 1 minute at
1500 RPM)
- 8. Pitot heating ON, test function;
ammeter must show rise
- 9. Pitot heating OFF
- 10. Strobe lights (ACLs) check ON, as required
- 11. Position lights, landing and taxi lights ON, as required

CAUTION

When taxiing at close range to other aircraft, or during night flight in clouds, fog or haze, the strobe lights should be switched OFF. The position lights must always be switched ON during night flight.

- 12. Idle RPM check, 600 to 800 RPM

END OF CHECKLIST

4A.3.5 TAXIING

1. Parking brake release
2. Brakes test on moving off
3. Flight instrumentation and avionics
(particularly directional gyro and
turn and bank indicator) check for correct indications

CAUTION

When taxiing on a poor surface select the lowest possible RPM to avoid damage to the propeller from stones or similar items.

CAUTION

Following extended operation on the ground, or at high ambient temperatures, the following indications of fuel vapor lock may appear:

- Arbitrary changes in idle RPM and fuel flow.
- Slow reaction of the engine to operation of throttle.
- Engine will not run with throttle in IDLE position.

CONTINUED

Remedy:

1. For about 1 to 2 minutes, or until the engine settles, run at a speed of 1800 to 2000 RPM. Oil and cylinder head temperatures must stay within limits.
2. Pull throttle back to IDLE to confirm smooth running.
3. Set throttle to 1200 RPM and mixture for taxiing, i.e., use mixture control lever to set the maximum RPM attainable.
4. Immediately before the take-off run set the mixture for take-off, apply full throttle and hold this position for 10 seconds.

NOTE

Vapor lock can be avoided if the engine is run at speeds of 1800 RPM or more. This results in lower fuel temperatures.

END OF CHECKLIST

4A.3.6 BEFORE TAKE-OFF

CAUTION

Before take-off, the engine must run on each tank for at least 1 minute at 1500 RPM.

CAUTION

~~For take off the adjustable backrests (if installed) must be fixed in the upright position.~~

- 1. Position airplane into wind if possible
- 2. Parking brake set
- 3. Adjustable backrests (if installed) verify upright position
And proper fixation
- 4. Safety harnesses on and fastened
- 5. Rear door check closed and locked
- 6. Front canopy closed and locked

CAUTION

When operating the canopy, ensure that there are no obstructions in between the canopy and the mating frame, for example seat belts, clothing, etc. When operating the locking handle do NOT apply undue force.

A slight downward pressure on the canopy may be required to ease handle operation.

- 7. Door warning light (DOOR or DOORS) check OFF
- 8. Fuel tank selector fullest tank

CONTINUED

- 9. Engine instruments in green sector
- 10. Circuit breakers pressed in
- 11. Fuel pressure indicator check (approx. 14 - 35 PSI)
- 12. Electrical fuel pump ON
- 13. Mixture control lever RICH (below 5000 ft)

NOTE

At a density altitude of 5000 ft or above or at high ambient temperatures a fully rich mixture can cause rough running of the engine or a loss of performance. The mixture should be set for smooth running of the engine.

- 14. Flaps check T/O
- 15. Trim check T/O
- 16. Flight controls free movement, correct sense
- 17. Throttle 2000 RPM
- 18. RPM lever pull back until a drop of 250 to 500 RPM is reached - HIGH RPM; cycle 3 times
- 19. Magneto check L - BOTH - R - BOTH
 Max. RPM drop . . 175 RPM
~~Max. difference . . . 50 RPM~~
 If the electronic ignition control unit is installed, the ignition status light must illuminate and extinguish after approximately 20 to 30 sec

*1 electric mag, 1 engine driven
Surrefly Ignition Module (SIM)*

CONTINUED

CAUTION

The lack of an RPM drop suggests a faulty grounding or incorrect ignition timing. In case of doubt the magneto check can be repeated with a leaner mixture, in order to confirm a problem. Even when running on only one magneto the engine should not run unduly roughly.

- | 20. Circuit breaker check in
- | 21. Voltmeter check in green range
- | 22. Throttle IDLE
- | 23. Parking brake release
- | 24. Alternate air check CLOSED
- | 25. Landing light ON as required
- | 26. Pitot heating ON as required

END OF CHECKLIST

4A.3.7 TAKE-OFF

Normal Take-Off Procedure

1. Transponder ON/ALT
2. RPM lever check HIGH RPM
3. Throttle MAX PWR (not abruptly)

WARNING

The proper performance of the engine at full throttle should be checked early in the take-off procedure, so that the take-off can be aborted if necessary.

A rough engine, sluggish RPM increase, or failure to reach take-off RPM (2680 ± 20 RPM) are reasons for aborting the take-off. If the engine oil is cold, an oil pressure in the yellow sector is permissible.

4. Elevator neutral
5. Rudder maintain direction

NOTE

In strong crosswinds steering can be augmented by use of the toe brakes. It should be noted, however, that this method increases the take-off roll, and should not generally be used.

6. Nose wheel lift-off at $v_R = 59$ KIAS

CONTINUED

- 7. Airspeed 67 KIAS (1200 kg, 2646 lb)
66 KIAS (1150 kg, 2535 lb)
60 KIAS (below 1000 kg,
2205 lb)

Above a Safe Height:

- 8. RPM lever 2400 RPM
- 9. Electrical fuel pump OFF
- 10. Landing light OFF

END OF CHECKLIST

4A.3.8 CLIMB

Procedure for Best Rate of Climb

- | | |
|--------------------------------|--|
| 1. Flaps | T/O |
| 2. Airspeed | 67 KIAS (1200 kg, 2646 lb) |
| | 66 KIAS (1150 kg, 2535 lb) |
| | 60 KIAS (1000 kg, 2205 lb) |
| | 54 KIAS (850 kg, 1874 lb) |
| 3. RPM lever | 2400 RPM |
| 4. Throttle | MAX PWR |
| 5. Mixture control lever | RICH, above 5000 ft hold
EGT constant |
| 6. Engine instruments | in green sector |
| 7. Trim | as required |
| 8. Electrical fuel pump | ON at high altitudes |

CAUTION

Operation at high altitudes with the electrical fuel pump OFF may cause vapor bubbles, resulting in intermittent low fuel pressure indications, sometimes followed by high fuel flow indications.

END OF CHECKLIST

Cruise Climb

1. Flaps UP
2. Airspeed 76 KIAS (1200 kg, 2646 lb)
73 KIAS (1150 kg, 2535 lb)
68 KIAS (1000 kg, 2205 lb)
60 KIAS (850 kg, 1874 lb)
3. RPM lever 2400 RPM
4. Throttle MAX PWR
5. Mixture control lever RICH, above 5000 ft hold
EGT constant
6. Engine instruments in green sector
7. Trim as required
8. Electrical fuel pump ON at high altitudes

CAUTION

Operation at high altitudes with the electrical fuel pump OFF may cause vapor bubbles, resulting in intermittent low fuel pressure indications, sometimes followed by high fuel flow indications.

END OF CHECKLIST

4A.3.9 CRUISE

- 1. Flaps UP
- 2. Throttle set performance according to table
- 3. RPM lever 1800 - 2400 RPM

NOTE

Favorable combinations of manifold pressure and RPM are given in Chapter 5.

NOTE

To optimize engine life the cylinder head temperature (CHT) should lie between 150 °F (66 °C) and 400 °F (204 °C) in continuous operation, and not rise above 435 °F (224 °C) in fast cruise.

NOTE

The oil temperature in continuous operation should lie between 165 °F (74 °C) and 220 °F (104 °C). If possible, the oil temperature should not remain under 180 °F (82 °C) for long periods, so as to avoid accumulation of condensation water.

- 4. Mixture set in accordance with 4A.3.10 - MIXTURE ADJUSTMENT

CONTINUED

- 5. Trim as required
- 6. Fuel tank selector as required
(max. difference 10 US gal
with Standard Tank,
8 US gal with Long Range
Tank)
- 7. Electrical fuel pump ON at high altitudes

CAUTION

Operation at high altitudes with the electrical fuel pump OFF may cause vapor bubbles, resulting in intermittent low fuel pressure indications, sometimes followed by high fuel flow indications.

NOTE

While switching from one tank to the other, the electrical fuel pump should be switched ON.

END OF CHECKLIST

4A.3.10 MIXTURE ADJUSTMENT**CAUTION**

1. The maximum permissible cylinder head temperature (500 °F (260 °C)) must never be exceeded.
2. The mixture control lever should always be moved slowly.
3. Before selecting a higher power setting the mixture control lever should, on each occasion, be moved slowly to fully RICH.
4. Care should always be taken that the cylinders do not cool down too quickly. The cooling rate should not exceed 50 °F (22.8 °C) per minute.

Best Economy Mixture

The best economy mixture setting may only be used up to a power setting of 75 %. In order to obtain the lowest specific fuel consumption at a particular power setting proceed as follows: Slowly pull the mixture control lever back towards LEAN until the engine starts to run roughly. Then push the mixture control lever forward just far enough to restore smooth running. At the same time the exhaust gas temperature (EGT) should reach a maximum.

The exact value of EGT can be obtained by pressing the far left button on the engine instrument unit VM 1000. In the Lean mode one bar represents 10 °F (4.6 °C).

CONTINUED

Best Power Mixture

The mixture can be set for maximum performance at all power settings. The mixture should first be set as for 'best economy'. The mixture should then be enriched until the exhaust gas temperature is approximately 100 °F (55 °C) lower.

This mixture setting produces the maximum performance for a given manifold pressure and is mainly used for high power settings (approximately 75 %).

END OF CHECKLIST

4A.3.11 DESCENT

- 1. Mixture control lever adjust as required for the altitude, operate slowly
- 2. RPM lever 1800 - 2400 RPM
- 3. Throttle as required
- 4. Electrical fuel pump ON at high altitudes

CAUTION

I

When reducing power, the change in cylinder head temperature should not exceed 50 °F (22.8 °C) per minute. This is normally guaranteed by the 'self adapting inlet'. An excessive cooling rate may occur however, when the engine is very hot and the throttle is reduced abruptly in a fast descent. This will be indicated by a flashing cylinder head temperature indication.

CAUTION

Operation at high altitudes with the electrical fuel pump OFF may cause vapor bubbles, resulting in intermittent low fuel pressure indications, sometimes followed by high fuel flow indications.

END OF CHECKLIST

4A.3.12 LANDING APPROACH

CAUTION

For landing the adjustable backrests (if installed) must be fixed in the upright position.

- ~~1. Adjustable backrests (if installed) adjust to the upright position described by a placard on the roll-over bar and verify proper fixation~~
- 2. Fuel selector fullest tank
- 3. Electrical fuel pump ON
- 4. Safety harnesses fastened
- 5. Airspeed reduce to operate flaps (108 KIAS)
- 6. Flaps T/O
- 7. Trim as required
- 8. Landing light as required

Before Landing:

- 9. Mixture control lever RICH
- 10. RPM lever HIGH RPM
- 11. Throttle as required
- 12. Airspeed reduce to operate flaps (91 KIAS)
- 13. Flaps LDG

CONTINUED

- 14. Approach speed 73 KIAS (1200 kg, 2646 lb)
 71 KIAS (1150 kg, 2535 lb)
 67 KIAS (1092 kg, 2407 lb)
 63 KIAS (1000 kg, 2205 lb)
 58 KIAS (850 kg, 1874 lb)

CAUTION

In conditions such as (e.g.) strong wind, danger of wind shear or turbulence a higher approach speed should be selected.

NOTE

In case of airplanes with a maximum landing mass less than the maximum permitted flight mass, a landing with a higher mass constitutes an abnormal operating procedure. Refer to Sections 2.7 - MASS (WEIGHT) and 4B.7 - LANDING WITH HIGH LANDING MASS.

END OF CHECKLIST

4A.3.13 GO-AROUND

1. Throttle MAX PWR
2. Airspeed 67 KIAS (1200 kg, 2646 lb)
66 KIAS (1150 kg, 2535 lb)
60 KIAS (1000 kg, 2205 lb)
54 KIAS (850 kg, 1874 lb)
3. Flaps T/O

Above a Safe Height:

4. RPM lever 2400 RPM
5. Airspeed 76 KIAS (1200 kg, 2646 lb)
73 KIAS (1150 kg, 2535 lb)
68 KIAS (1000 kg, 2205 lb)
60 KIAS (850 kg, 1874 lb)
6. Flaps UP
7. Electrical fuel pump OFF

END OF CHECKLIST

4A.3.14 AFTER LANDING

- 1. Throttle IDLE
- 2. Brakes as required
- 3. Electrical fuel pump OFF
- 4. Transponder OFF / STBY
- 5. Pitot heating OFF
- 6. Avionics as required
- 7. Lights as required
- 8. Flaps UP

END OF CHECKLIST

4A.3.15 ENGINE SHUT-DOWN

1. Parking brake set
2. Engine instruments check
3. Avionics Master switch OFF
4. All electrical equipment OFF
5. Throttle 1000 RPM
6. Ignition check OFF until RPM drops
noticeably, then immediately
BOTH again

7. Mixture control lever LEAN - shut engine off
8. Ignition switch OFF
9. Master switch (ALT/BAT) OFF

END OF CHECKLIST

4A.3.16 POST-FLIGHT INSPECTION

- 1. Ignition switch OFF, remove key
- 2. Master switch (BAT) ON
- 3. Avionics Master switch ON
- 4. ELT check activated:
listen on 121.5 MHz
- 5. Avionics Master switch OFF
- 6. Master switch (BAT) OFF
- 7. Parking brake release, use chocks
- 8. Airplane moor, if unsupervised for
extended period

NOTE

If the airplane is not operated for more than 5 days, the long-term parking procedure should be applied. If the airplane is not operated for more than 30 days, the storage procedure should be applied. Both procedures are described in the Airplane Maintenance Manual (Doc. No. 6.02.01) in Chapter 10.

END OF CHECKLIST

4A.3.17 FLIGHT IN RAIN

NOTE

Performance deteriorates in rain; this applies particularly to the take-off distance and to the maximum horizontal speed. The effect on the flight characteristics is minimal. Flight through very heavy rain should be avoided because of the associated visibility problems.

4A.3.18 REFUELING

CAUTION

Before refueling, the airplane must be connected to electrical ground. Grounding points: unpainted areas (latches) on steps, left and right.

4A.3.19 FLIGHT AT HIGH ALTITUDE

At high altitudes the provision of oxygen for the occupants is necessary. Legal requirements for the provision of oxygen should be adhered to.

Also see Section 2.11 - OPERATING ALTITUDE.

CHAPTER 4B

ABNORMAL OPERATING PROCEDURES

	Page
4B.1 PRECAUTIONARY LANDING	4B-2
4B.2 INSTRUMENT INDICATIONS OUTSIDE OF GREEN RANGE ..	4B-4
4B.3 FAILURES IN THE ELECTRICAL SYSTEM	4B-5
4B.4 TAKE-OFF FROM A SHORT GRASS STRIP	4B-7
4B.5 FAILURES IN FLAP OPERATING SYSTEM	4B-9
4B.6 FAILURES IN ELECTRICAL RUDDER PEDAL ADJUSTMENT .	4B-10
4B.7 LANDING WITH HIGH LANDING MASS	4B-11
4B.8 STARTING THE ENGINE WITH EXTERNAL POWER	4B-12

4B.1 PRECAUTIONARY LANDING

NOTE

A landing of this type is only necessary when there is a reasonable suspicion that due to fuel shortage, weather conditions, or at nightfall the possibility of endangering the airplane and its occupants by continuing the flight cannot be excluded. The pilot is required to decide whether or not a controlled landing in a field represents a lower risk than the attempt to reach the target airfield under all circumstances.

NOTE

If no level landing area is available, a landing on an upward slope should be sought.

1. Select appropriate landing area.
2. Consider wind.
3. Approach: If possible, the landing area should be overflown at a suitable height in order to recognize obstacles. The degree of offset at each part of the circuit will allow the wind speed and direction to be assessed.

4. Airspeed 76 KIAS (1200 kg, 2646 lb)
73 KIAS (1150 kg, 2535 lb)
68 KIAS (1000 kg, 2205 lb)
60 KIAS (850 kg, 1874 lb)

5. ATC advise

CONTINUED

On Final Approach:

- 6. Flaps LDG
- 7. Safety harnesses tighten
- 8. Touchdown with the lowest possible
airspeed

CAUTION

If sufficient time is remaining, the risk in the event of a collision with obstacles can be reduced as follows:

- Fuel tank selector OFF
- Ignition switch OFF
- Master switch (ALT/BAT) OFF

END OF CHECKLIST

4B.2 INSTRUMENT INDICATIONS OUTSIDE OF GREEN RANGE

(a) High Oil Pressure When Starting in Low Ambient Temperatures

- Reduce RPM and re-check oil pressure at a higher oil temperature.
- If on reducing the RPM the indicated oil pressure does not change, it is probable that the fault lies in the oil pressure indication. Terminate flight preparation.

(b) High Manifold Pressure

If the manifold pressure indicator is clearly above the green range, the reading is faulty. In this case the performance settings should be undertaken by means of the lever settings. The airplane should be serviced.

(c) Oil Temperature

- A constant reading of the oil temperature of 26 °F (-3 °C) or 317 °F (158 °C) suggests a faulty oil temperature sensor. The airplane should be serviced.

(d) Cylinder Head Temperature and Exhaust Gas Temperature

A very low reading of CHT or EGT for a single cylinder may be the result of a loose sensor. In this case the reading will indicate the temperature of the engine compartment. The airplane should be serviced.

END OF CHECKLIST

4B.3 FAILURES IN THE ELECTRICAL SYSTEM

(a) 'Low Voltage' Caution (VOLT or LOW VOLTS)

This caution is indicated when the normal on-board voltage (28 V) drops below 24 V.

Possible reasons are:

- A fault in the power supply.
- RPM too low.

(i) 'Low Voltage' Caution on the Ground:

1. Engine speed 1200 RPM
2. Electrical equipment OFF
3. Ammeter check

If the caution light does not go out, and the ammeter flashes and reads zero:

- Terminate flight preparation.

(ii) 'Low Voltage' Caution During Flight:

1. Electrical equipment OFF if not needed
2. Ammeter check

If the caution light does not go out, and the ammeter flashes and reads zero:

- Follow procedure in 3.7.2 (b) - ALTERNATOR FAILURE.

(iii) 'Low Voltage' Caution During Landing:

- Follow (i) after landing.

END OF CHECKLIST

Doc. # 6.01.01-E	Rev. 8	01-Dec-2010	Page 4B - 5
------------------	--------	-------------	-------------

(b) Electronic Ignition Control Unit

If the electronic ignition control unit is installed but inoperative, the white status light for the ignition (IGN or IGNITION) will be illuminated, and the conventional magneto ignition will take over the ignition control.

The flight can be continued normally. However, fuel consumption will slightly increase, and engine starting will become difficult.

END OF CHECKLIST

4B.4 TAKE-OFF FROM A SHORT GRASS STRIP

- 1. Brakes apply
- 2. Flaps T/O
- 3. Throttle MAX PWR
- 4. Elevator (control stick) fully aft
- 5. Brakes release
- 6. Hold direction using rudder

NOTE

In strong crosswinds steering can be augmented by use of the toe brakes. It should be noted, however, that this method increases the take-off roll, and should not generally be used.

- 7. Elevator (control stick) release slowly, when nose wheel has lifted
Allow airplane to lift off as soon as possible and increase speed at low level

- 8. Airspeed 67 KIAS (1200 kg, 2646 lb)
66 KIAS (1150 kg, 2535 lb)
60 KIAS (1000 kg, 2205 lb)
54 KIAS (850 kg, 1874 lb)

- 9. RPM lever 2400 RPM, above safe altitude

CONTINUED

- 10. Flaps UP, above safe altitude
- 11. Electrical fuel pump OFF, above safe altitude
- 12. Landing light as required

END OF CHECKLIST

4B.5 FAILURES IN FLAP OPERATING SYSTEM

Failure in Position Indication or Function

- Check flap position visually.
- Keep airspeed in white sector.
- Re-check all positions of the flap switch.

Modified Approach Procedure Depending on the Available Flap Setting

■ (a) *Only UP or T/O Available:*

■	Airspeed	76 KIAS (1200 kg, 2646 lb)
		73 KIAS (1150 kg, 2535 lb)
		68 KIAS (1000 kg, 2205 lb)
		60 KIAS (850 kg, 1874 lb)

Land at a flat approach angle, use throttle to control airplane speed and rate of descent.

(b) *Only LDG Available:*

Perform normal landing.

END OF CHECKLIST

4B 6 FAILURES IN ELECTRICAL RUDDER PEDAL ADJUSTMENT

Runaway of Electrical Rudder Pedal Adjustment (Optional Equipment, OÄM 40-251)

NOTE

The circuit breaker for the rudder pedal adjustment is located below the related switch, on the rear wall of the leg room.

1. Circuit breaker pull

END OF CHECKLIST

4B.7 LANDING WITH HIGH LANDING MASS

NOTE



This Section only applies to airplanes with a maximum landing mass less than the maximum flight mass. All landings with a current flight mass not exceeding the maximum permissible landing mass constitutes a normal operating procedure. Refer to Sections 2.7 - MASS (WEIGHT) and 4A.3.12 - LANDING APPROACH.

NOTE

The maximum landing mass given in Chapter 2 is the highest mass for landing conditions at the maximum descent velocity. This velocity was used in the strength calculations to determine the landing gear loads during a particularly hard landing.

Perform landing approach and landing according to Chapter 4A, but maintain an increased airspeed during landing approach.

- Approach speed 73 KIAS (1200 kg, 2646 lb)
71 KIAS (1150 kg, 2535 lb)

WARNING

Damage of the landing gear can result from a hard landing with a flight mass above the maximum landing mass.

END OF CHECKLIST

4B.8 STARTING THE ENGINE WITH EXTERNAL POWER

WARNING

The use of an external power supply for engine starting with an empty airplane battery is not permitted if the subsequent flight is intended to be an IFR flight. In this case the airplane battery must be charged first.

WARNING

The external power supply must be operated by a person made aware of the associated procedures. Special care is required due to the proximity of the propeller area.

NOTE

Starting the engine with external power is recommended in particular at ambient temperatures below 0 °C (32 °F), to reduce wear and abuse to the engine and electrical system.

1. Pre-flight inspection complete
2. Rudder pedals adjusted
3. Passengers instructed
4. Safety harnesses all on and fastened
5. Baggage check, secured
6. Rear door closed and locked
7. Door lock (if installed) unblocked, key removed

CONTINUED

CAUTION

When operating the canopy, ensure that there are no obstructions between the canopy and the mating frame, for example seat belts, clothing, etc. When operating the locking handle do NOT apply undue force.

A slight downward pressure on the canopy may be required to ease handle operation.

- 8. Front canopy Position 1 or 2 (“Cooling gap”)
- 9. Canopy lock (if installed) unblocked, key removed
- 10. Parking brake set
- 11. Flight controls free movement
- 12. Trim wheel T/O
- 13. Throttle IDLE
- 14. RPM lever HIGH RPM
- 15. Mixture control lever LEAN
- 16. Friction device, throttle quadrant adjusted
- 17. Alternate air CLOSED
- 18. Alternate static valve CLOSED, if installed
- 19. Avionics Master switch OFF
- 20. Essential Bus switch OFF, if installed

CAUTION

When the essential bus is switched ON, the battery will not be charged unless the essential tie relay bypass (OAM 40-126) is installed.

CONTINUED

- 21. External power connect
- 22. Master switch (BAT) ON
- 23. Annunciator panel test (see Section 7.11)
- 24. Fuel tank selector on full tank

WARNING

Never move the propeller by hand while the ignition is switched on, as it may result in serious personal injury.

Never try to start the engine by hand.

- 25. Starting engine procedure refer to 4A.3.3 execute
- 26. External power disconnect, close access panel
- 27. Ammeter check
- 28. Master switch (ALT) OFF, note decrease of ammeter reading
- 29. Master switch (ALT) ON

END OF CHECKLIST

CHAPTER 5

PERFORMANCE

	Page
5.1 INTRODUCTION	5-2
5.2 USE OF THE PERFORMANCE TABLES AND DIAGRAMS	5-2
5.3 PERFORMANCE TABLES AND DIAGRAMS	5-3
5.3.1 AIRSPEED CALIBRATION	5-3
5.3.2 TABLE FOR SETTING ENGINE PERFORMANCE	5-4
5.3.3 PRESSURE ALTITUDE - DENSITY ALTITUDE	5-7
5.3.4 STALLING SPEEDS	5-8
5.3.5 WIND COMPONENTS	5-9
5.3.6 TAKE-OFF DISTANCE	5-10
5.3.7 CLIMB PERFORMANCE - TAKE-OFF CLIMB	5-13
5.3.8 CLIMB PERFORMANCE - CRUISE CLIMB	5-15
5.3.9 CRUISING (TRUE AIRSPEED TAS)	5-17
5.3.10 LANDING DISTANCE - FLAPS LDG	5-18
5.3.11 LANDING DISTANCE - FLAPS UP	5-21
5.3.12 GRADIENT OF CLIMB ON GO-AROUND	5-24
5.3.13 APPROVED NOISE DATA	5-24

5.1 INTRODUCTION

The performance tables and diagrams on the following pages are presented so that, on the one hand, you can see what performance you can expect from your airplane, while on the other they allow comprehensive and sufficiently accurate flight planning. The values in the tables and the diagrams were obtained in the framework of the flight trials using an airplane and power-plant in good condition, and corrected to the conditions of the International Standard Atmosphere (ISA = 15 °C / 59 °F and 1013.25 hPa / 29.92 inHg at sea level).

The performance diagrams do not take into account variations in pilot experience or a poorly maintained airplane. The performances given can be attained if the procedures quoted in this manual are applied, and the airplane has been well maintained.

5.2 USE OF THE PERFORMANCE TABLES AND DIAGRAMS

In order to illustrate the influence of a number of different variables, the performance data is reproduced in the form of tables or diagrams. These contain sufficiently detailed information so that conservative values can be selected and used for the determination of adequate performance data for the planned flight.

Where appropriate, any flight performance degradation resulting from the absence of wheel fairings is given as a percentage.

The installation of the optional fairings on the main landing gear struts and/or nose landing gear strut has only minor effects on the flight performance of the DA 40. Therefore, no change applies to the performance tables and diagrams.

5.3 PERFORMANCE TABLES AND DIAGRAMS

5.3.1 AIRSPEED CALIBRATION

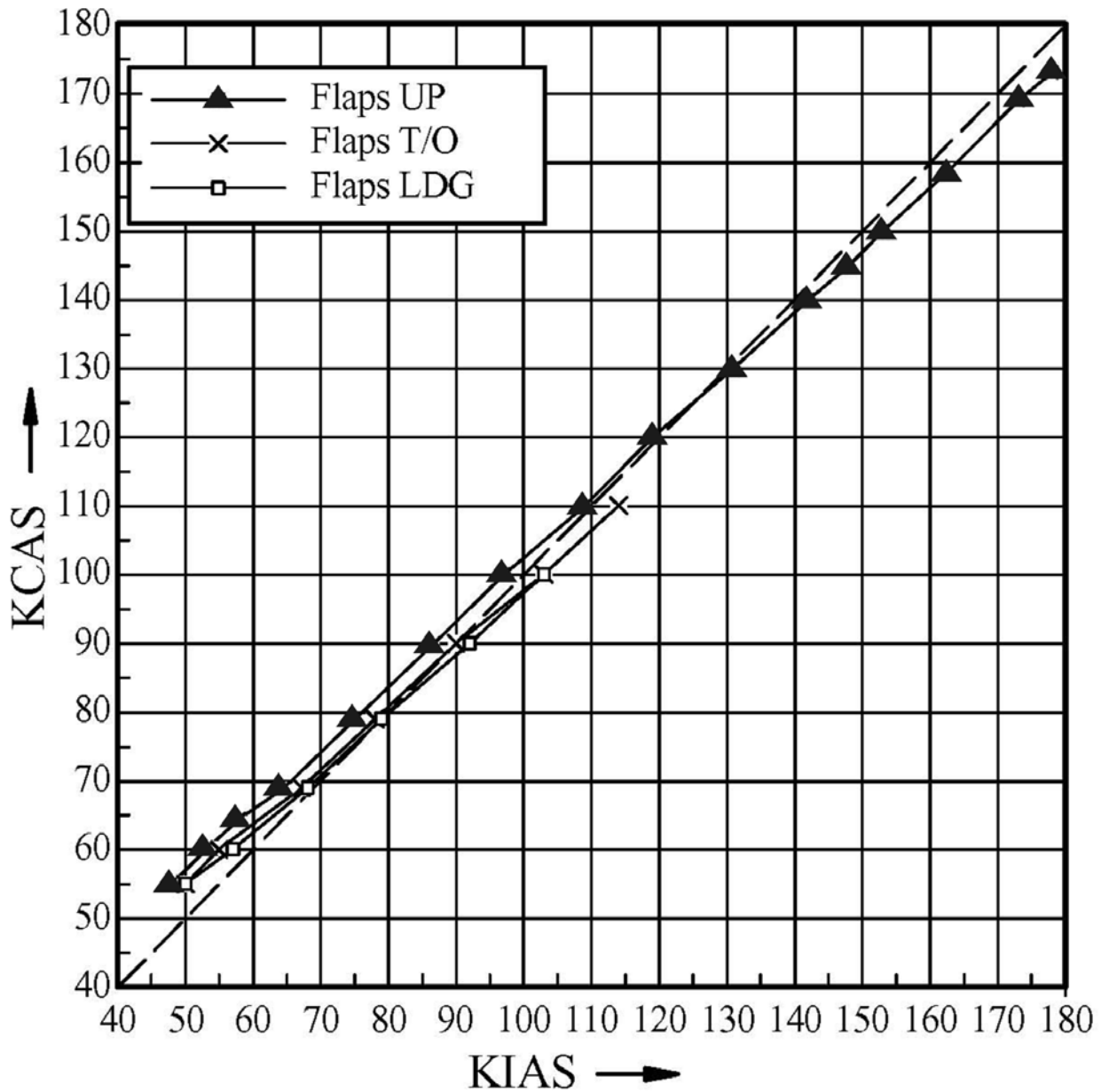

5.3.2 TABLE FOR SETTING ENGINE PERFORMANCE**NOTE**

If the Long Range Tank is installed:

Auxiliary fuel below 3 US gal cannot be indicated by the system. If a fuel indicator shows 16 US gal and the auxiliary fuel indicator reads 0 US gal on the same side, for in-flight fuel consumption / flight planning a fuel quantity available of 16 US gal must be assumed.

			Engine Power as % of Max. Take-Off Power						
			45 %				55 %		
	RPM		1800	2000	2200	2400	2000	2200	2400
Fuel Flow [US gal/h]	Best Economy		5.8	6	6.3	6.6	7	7.2	7.5
	Best Power		-	-	7.3	7.7	-	8.5	8.7
ISA	[°C]	[°F]	Manifold Pressure (MP) [inHg]						
MSL	15	59	22.7	21.3	20.2	19.0	23.9	22.4	21.2
1000	13	55	22.4	21.0	19.9	18.7	23.6	22.2	21.0
2000	11	52	22.1	20.7	19.6	18.4	23.3	21.9	20.7
3000	9	48	21.8	20.4	19.3	18.2	23.0	21.6	20.4
4000	7	45	21.5	20.2	19.0	17.9	22.7	21.2	20.1
5000	5	41	21.2	19.9	18.7	17.6	22.3	20.9	19.8
6000	3	38	20.9	19.6	18.4	17.4	22.0	20.6	19.5
7000	1	34	20.5	19.3	18.2	17.1	21.7	20.3	19.3
8000	-1	31	20.2	19.0	17.9	16.9	21.3	20.0	19.0
9000	-3	27	19.9	18.7	17.6	16.6	21.1	19.7	18.7
10000	-5	23	19.6	18.4	17.3	16.3	-	19.4	18.4
11000	-7	19	19.3	18.2	17.0	16.1		19.1	18.1
12000	-9	16	-	17.9	16.7	15.8		-	17.8
13000	-11	12		17.6	16.4	15.5			17.6
14000	-13	9		-	16.1	15.3			-
15000	-15	6			15.8	15.0			
16000	-17	2			15.5	14.7			
17000	-19	-2			-	14.5			

			Engine Power as % of Max. Take-Off Power				
			65 %			75 %	
	RPM		2000	2200	2400	2200	2400
Fuel Flow [US gal/h]	Best Economy		7.9	8.2	8.5	9.2	9.5
	Best Power		-	9.5	9.8	10.7	11
ISA	[°C]	[°F]	Manifold Pressure (MP) [inHg]				
MSL	15	59	26.8	24.9	23.4	27.3	25.8
1000	13	55	26.4	24.5	23.2	26.8	25.5
2000	11	52	26.0	24.2	22.9	26.5	25.2
3000	9	48	25.7	23.8	22.6	26.1	24.8
4000	7	45	25.4	23.5	22.3	-	24.5
5000	5	41	-	23.1	22.0		24.1
6000	3	38		22.8	21.7		-
7000	1	34		22.4	21.4		
8000	-1	31		-	21.0		
9000	-3	27			20.7		
10000	-5	23			-		

The areas shaded grey under each RPM heading are the recommended bands.

Correcting the Table for Variation from Standard Temperature

- At ISA + 15 °C (ISA + 27 °F) the performance values fall by approx. 3 % of the power selected according to the above table.
- At ISA - 15 °C (ISA - 27 °F) the performance values rise by approx. 3 % of the power selected according to the above table.

5.3.3 PRESSURE ALTITUDE - DENSITY ALTITUDE

Conversion from pressure altitude to density altitude.

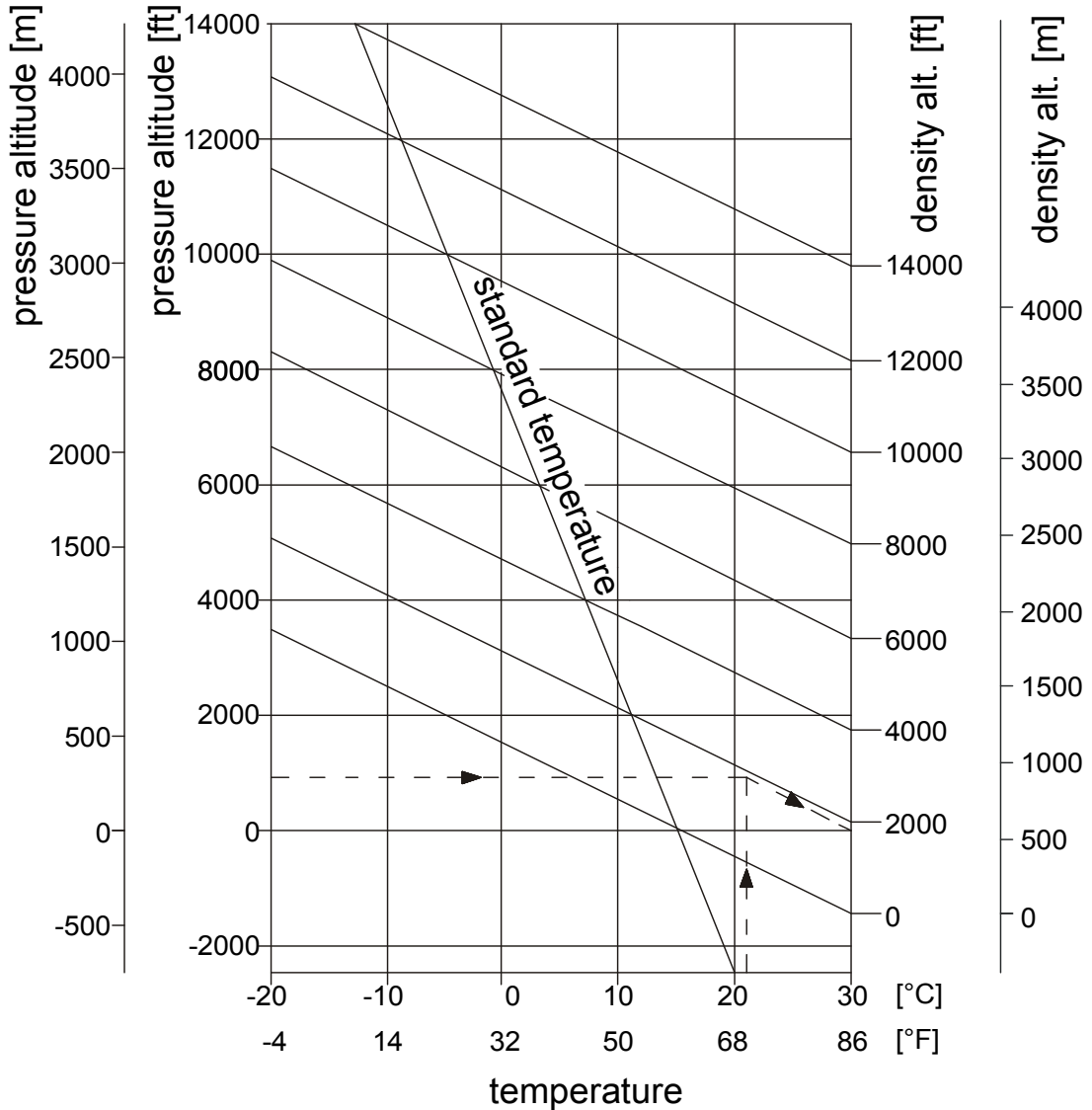

- Example:
1. Set 1013.25 hPa on altimeter and read pressure altitude (900 ft).
 2. Establish ambient temperature (+21 °C (70 °F)).
 3. Read off density altitude (1800 ft).

Result: From a performance calculation standpoint the airplane is at 1800 ft.

5.3.4 STALLING SPEEDS

Airspeeds in KIAS

Mass: 980 kg (2161 lb)

980 kg		Bank Angle			
		0°	30°	45°	60°
Flaps	UP	47	52	58	73
	T/O	44	51	58	72
	LDG	42	49	57	71

Mass: 1150 kg (2535 lb)

1150 kg		Bank Angle			
		0°	30°	45°	60°
Flaps	UP	52	57	66	79
	T/O	51	55	64	78
	LDG	49	55	62	76

Mass: 1200 kg (2646 lb) (if MÄM 40-227 is carried out)

1200 kg		Bank Angle			
		0°	30°	45°	60°
Flaps	UP	53	58	68	83
	T/O	52	57	67	81
	LDG	52	57	66	80

5.3.5 WIND COMPONENTS

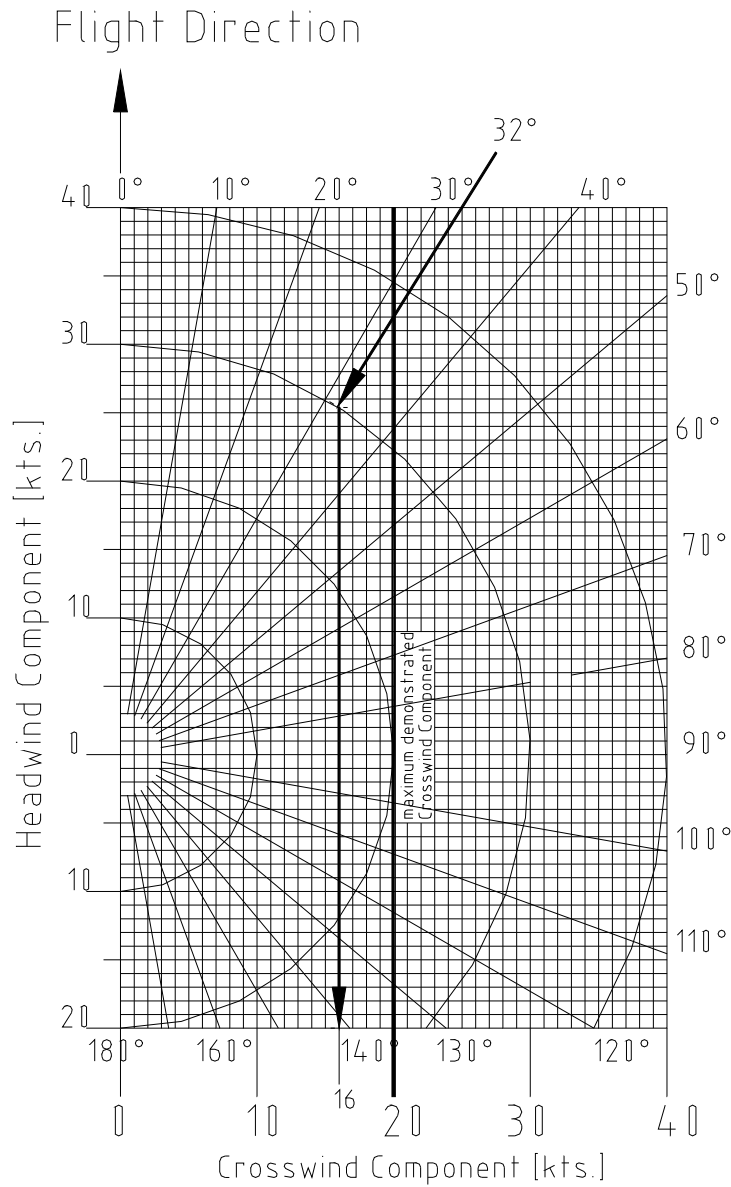

Example: Flight direction : 360°
 Wind : 32°/30 kts
 Result: Crosswind component : 16 kts
 Max. demonstrated crosswind component : 20 kts

5.3.6 TAKE-OFF DISTANCE

- Conditions:
- Throttle MAX PWR
 - RPM lever 2700 RPM
 - Flaps T/O
 - Lift-off speed approx. 59 KIAS

 - Climb-out speed 67 KIAS (1200 kg, 2646 lb)
66 KIAS (1150 kg, 2535 lb)
60 KIAS (below 1000 kg,
2205 lb)

 - Runway level, asphalt surface

WARNING

Poor maintenance condition of the airplane, deviation from the given procedures as well as unfavorable external factors (high temperature, rain, unfavorable wind conditions, including cross-wind) will increase the take-off distance.

CAUTION

For a safe take-off the take-off run available (TORA) should be at least equal to the take-off distance over a 50 ft (15 m) obstacle.

CAUTION

The figures in the following NOTE are typical values. On wet ground or wet soft grass covered runways the take-off roll may become significantly longer than stated below. In any case the pilot must allow for the condition of the runway to ensure a safe take-off.

NOTE

For take-off from dry, short-cut grass covered runways, the following corrections must be taken into account, compared to paved runways (typical values, see CAUTION above):

- Grass up to 5 cm (2 in) long: 10 % increase in take-off roll.
- Grass 5 to 10 cm (2 to 4 in) long: 15 % increase in take-off roll.
- Grass longer than 10 cm (4 in): at least 25 % increase in take-off roll.
- Grass longer than 25 cm (10 in): take-off should not be attempted.

NOTE

On wet grass, a further 10 % increase in take-off roll must be expected.

NOTE

An uphill slope of 2 % (2 m per 100 m, or 2 ft per 100 ft) results in an increase in the take-off distance of approximately 10 %. The effect on the take-off roll can be greater.

* Refer to revisions for T/O Distances

DA 40 - TAKE-OFF DISTANCES

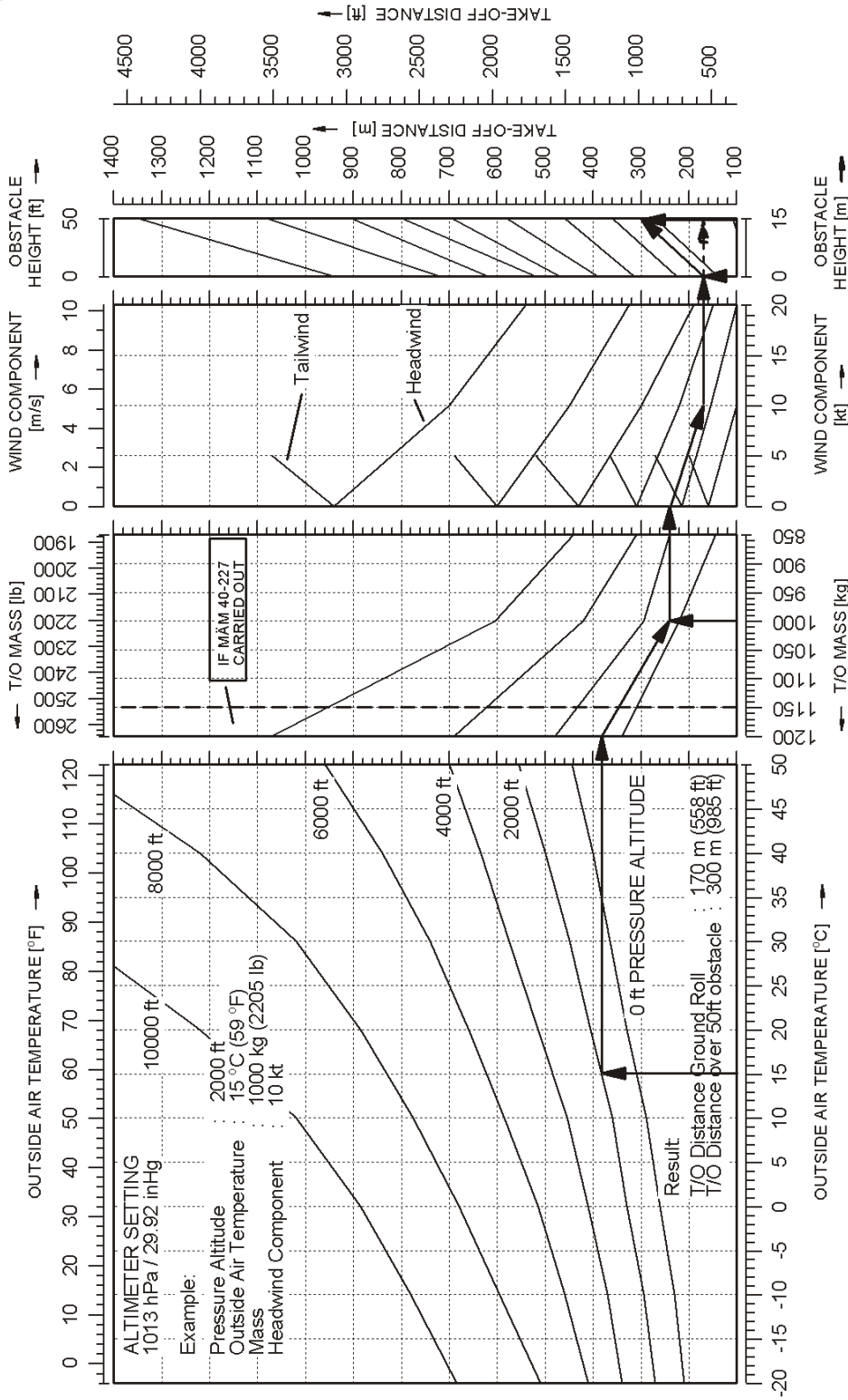

5.3.7 CLIMB PERFORMANCE - TAKE-OFF CLIMB

- Conditions:
- Throttle MAX PWR
 - RPM lever 2400 RPM
 - Flaps T/O

- I**
- Airspeed 67 KIAS (1200 kg, 2646 lb)
 - 66 KIAS (1150 kg, 2535 lb)
 - 60 KIAS (1000 kg, 2205 lb)
 - 54 KIAS (850 kg, 1874 lb)

* Refer to revisions for Climb performance

DA 40 - CLIMB PERFORMANCE - TAKE OFF CLIMB

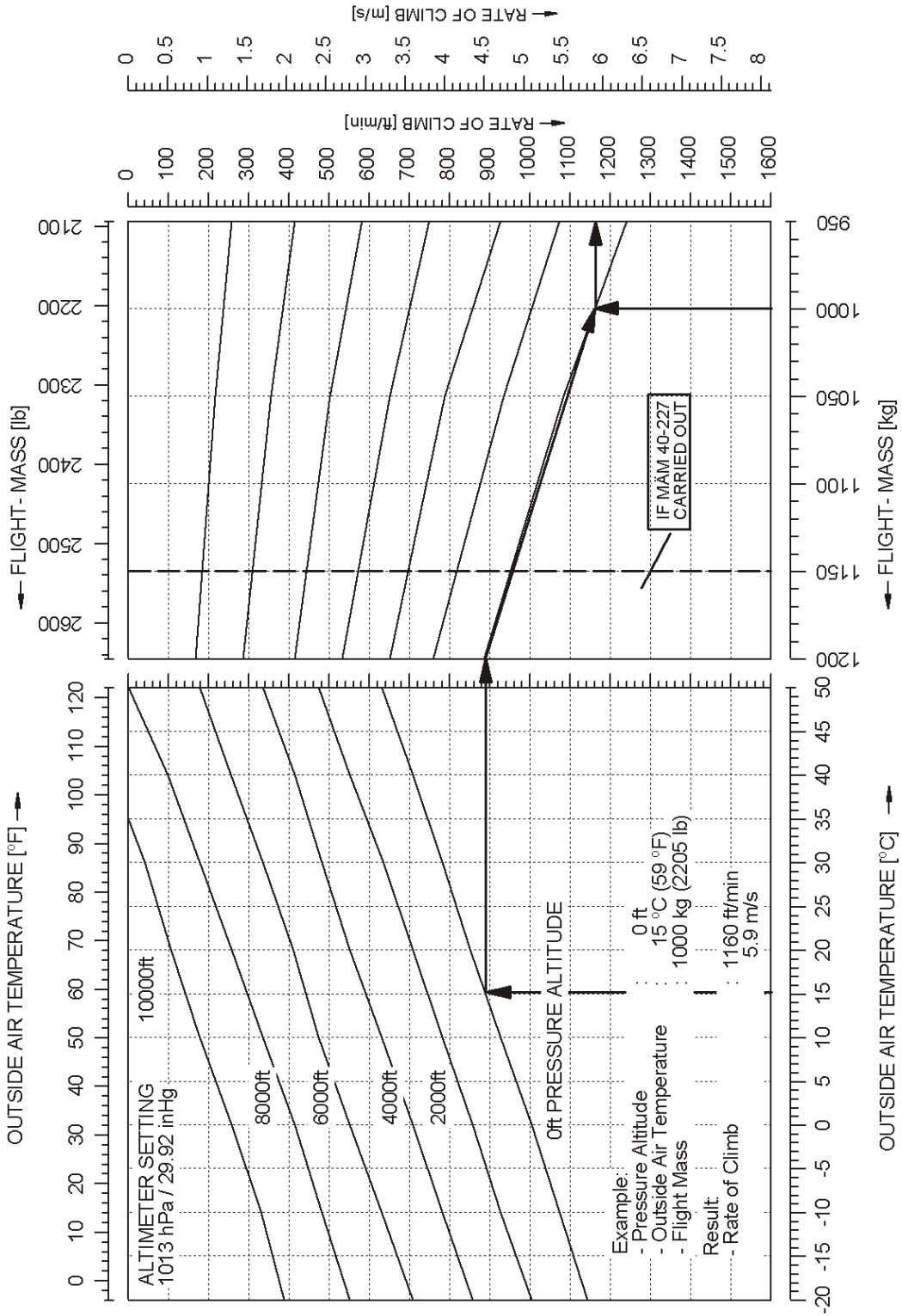

5.3.8 CLIMB PERFORMANCE - CRUISE CLIMB

Conditions:

- Throttle MAX PWR
- RPM lever 2400 RPM
- Flaps UP

I

- Airspeed 76 KIAS (1200 kg, 2646 lb)
- 73 KIAS (1150 kg, 2535 lb)
- 68 KIAS (1000 kg, 2205 lb)
- 60 KIAS (850 kg, 1874 lb)

* Refr to revisions for cruise climb performance

DA 40 - CLIMB PERFORMANCE - CRUISE CLIMB

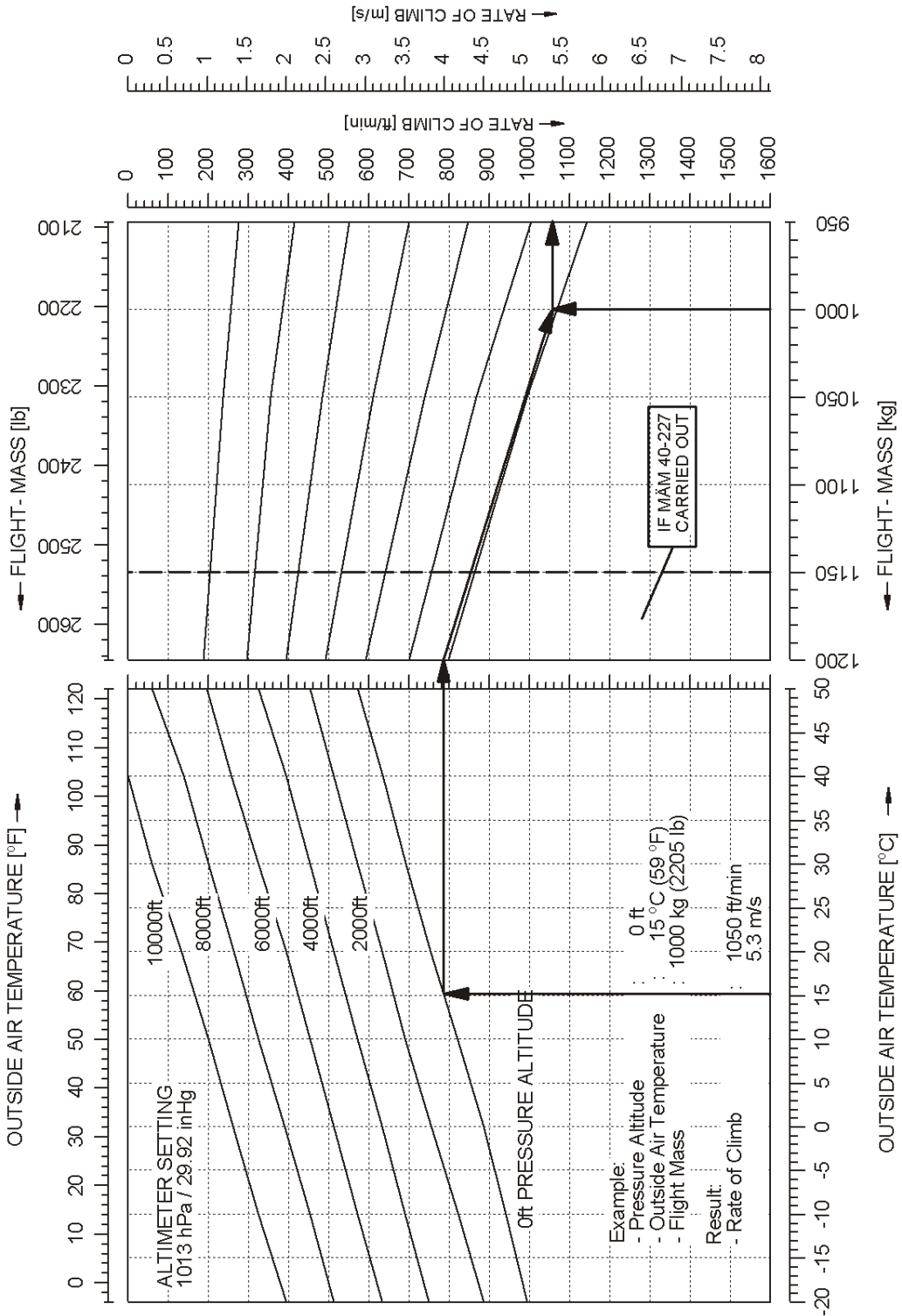

5.3.9 CRUISING (TRUE AIRSPEED TAS)

Diagram to establish true airspeed (TAS) at a given power setting.

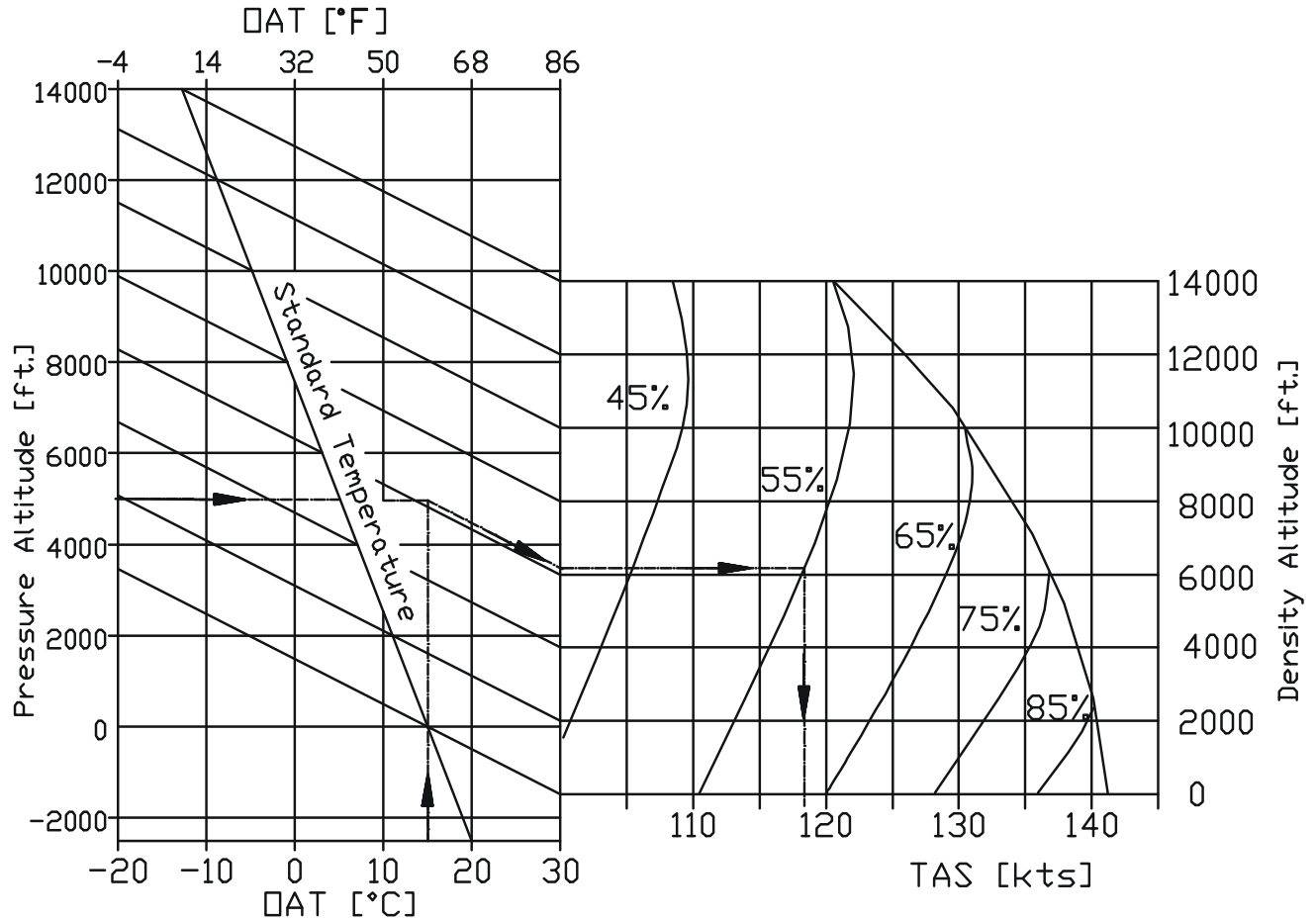

Example: Pressure altitude 5000 ft
 Temperature 15 °C (59 °F)
 Power setting 55 %

Result: True Airspeed (TAS) 118 kts

CAUTION

In case of operation without wheel fairings the cruising speed reduces by approximately 5 %.

CAUTION

For a safe landing the landing distance available (LDA) should be at least equal to the landing distance over a 50 ft (15 m) obstacle.

CAUTION

The figures in the following NOTE are typical values. On wet ground or wet soft grass covered runways the landing distance may become significantly longer than stated below. In any case the pilot must allow for the condition of the runway to ensure a safe landing.

NOTE

For landings on dry, short-cut grass covered runways, the following corrections must be taken into account, compared to paved runways (typical values, see CAUTION above):

- Grass up to 5 cm (2 in) long: 5 % increase in landing roll.
- Grass 5 to 10 cm (2 to 4 in) long: 15 % increase in landing roll.
- Grass longer than 10 cm (4 in): at least 25 % increase in landing roll.

NOTE

On wet grass, a further 10 % increase in landing roll must be expected.

NOTE

A downhill slope of 2 % (2 m per 100 m, or 2 ft per 100 ft) results in an increase in the landing distance of approximately 10 %. The effect on the landing roll can be greater.

DA 40 - LANDING DISTANCES - FLAPS LDG

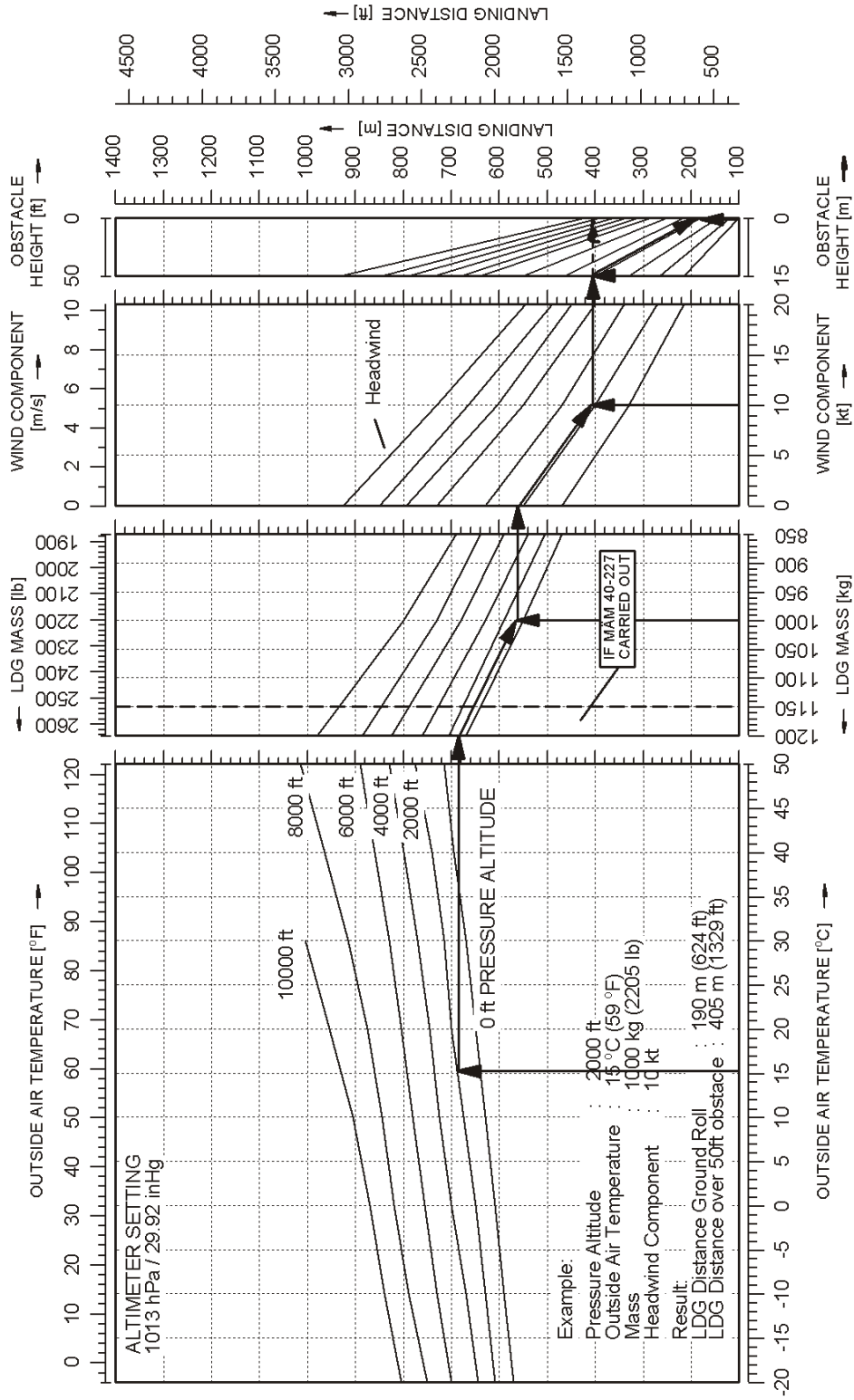

5.3.11 LANDING DISTANCE - FLAPS UP

- Conditions:
- Throttle IDLE
 - RPM lever HIGH RPM
 - Flaps UP
 - Approach speed 73 KIAS (1200 kg, 2646 lb)
71 KIAS (1150 kg, 2535 lb)
63 KIAS (1000 kg, 2205 lb)
58 KIAS (850 kg, 1874 lb)
 - Runway level, asphalt surface

NOTE

A landing mass above 1150 kg (2535 lb) up to 1200 kg (2646 lb) will increase the landing distance over a 50 ft (15 m) obstacle and the landing ground roll distance up to 6%.

Values for ISA and MSL, at 1150 kg (2535 lb)	
Landing distance over a 50 ft (15 m) obstacle	approx. 775 m (2543 ft)
Ground roll	approx. 471 m (1545 ft)

WARNING

Poor maintenance condition of the airplane, deviation from the given procedures as well as unfavorable external factors (high temperature, rain, unfavorable wind conditions, including cross-wind) will increase the landing distance.

CAUTION

For a safe landing the landing distance available (LDA) should be at least equal to the landing distance over a 50 ft (15 m) obstacle.

CAUTION

The figures in the following NOTE are typical values. On wet ground or wet soft grass covered runways the landing distance may become significantly longer than stated below. In any case the pilot must allow for the condition of the runway to ensure a safe landing.

NOTE

For landings on dry, short-cut grass covered runways, the following corrections must be taken into account, compared to paved runways (typical values, see CAUTION above):

- Grass up to 5 cm (2 in) long: 5 % increase in landing roll.
- Grass 5 to 10 cm (2 to 4 in) long: 15 % increase in landing roll.
- Grass longer than 10 cm (4 in): at least 25 % increase in landing roll.

NOTE

On wet grass, a further 10 % increase in landing roll must be expected.

NOTE

A downhill slope of 2 % (2 m per 100 m or 2 ft per 100 ft) results in an increase in the landing distance of approximately 10 %. The effect on the landing roll can be greater.

Landing Distance - Flaps UP

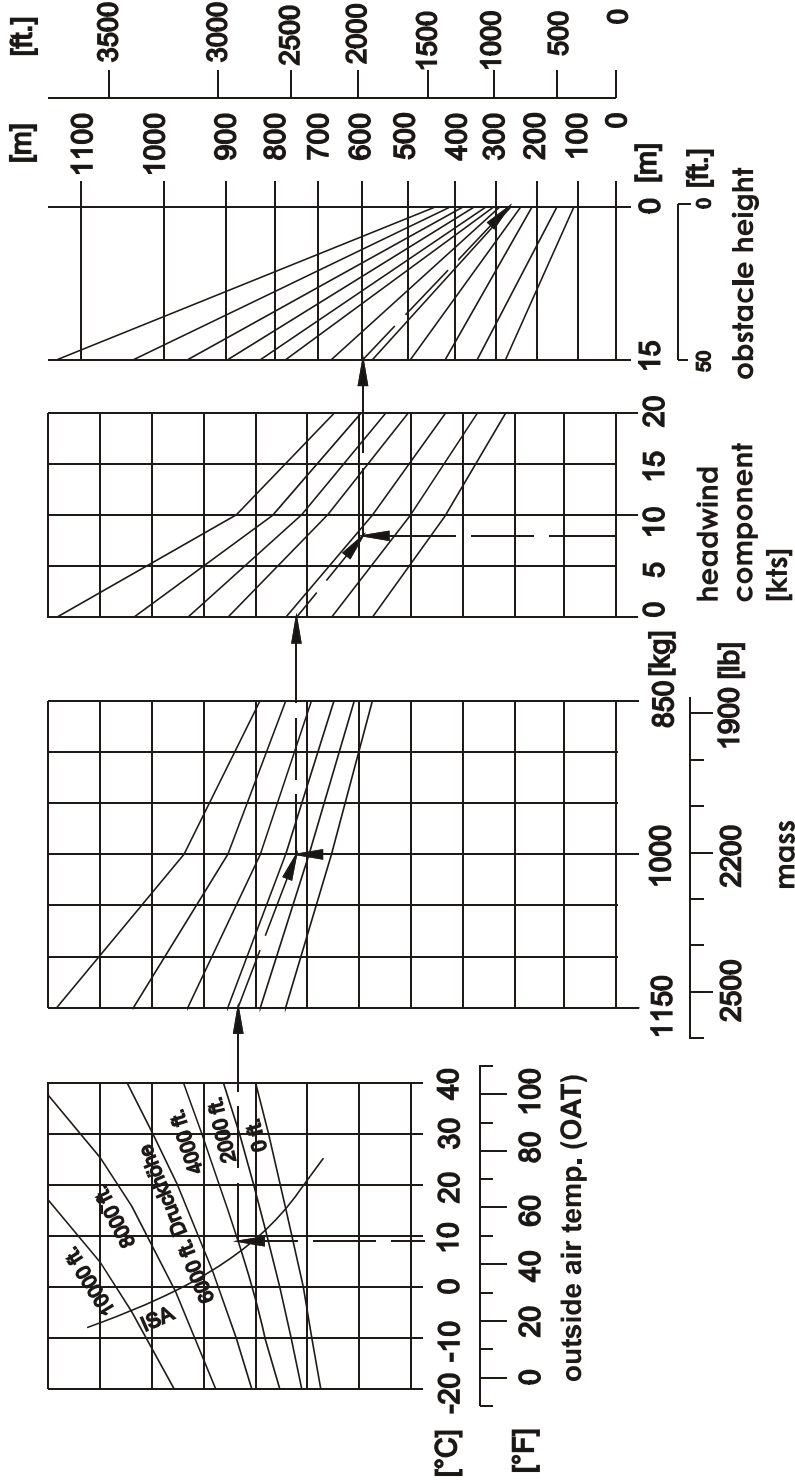

Result:

Example:
 Pressure altitude : 4000 ft Landing distance over 50 ft obstacle : approx. 580 m (1903 ft)
 OAT : 8 °C (46 °F) Ground roll : approx. 270 m (886 ft)
 Mass : 1000 kg (2205 lb)
 Headwind comp. : 8 kts

5.3.12 GRADIENT OF CLIMB ON GO-AROUND

The DA 40 reaches a constant gradient of climb of 7.0 % in the following condition:

- Mass max. flight mass (1150 kg, 2535 lb)
- Power setting Take-off
- Flaps LDG
- Airspeed 70 KIAS
- ISA, MSL

■ If MÄM 40-227 is carried out:

■ The DA 40 reaches a constant gradient of climb of 7.0 % in the following condition:

- - Mass max. flight mass (1200 kg, 2646 lb)
- - Power setting Take-off
- - Flaps LDG
- - Airspeed 73 KIAS
- - ISA, MSL

5.3.13 APPROVED NOISE DATA

ICAO Annex 16 Chapter X : 69.28 dB(A)
 JAR-36 Subpart C : 69.28 dB(A)

■ If MÄM 40-227 is carried out:

- ICAO Annex 16 Chapter X : 78.4 dB(A)
- JAR-36 Subpart C : 78.4 dB(A)

CHAPTER 6

MASS AND BALANCE

	Page
6.1 INTRODUCTION	6-2
6.2 DATUM PLANE	6-3
6.3 MASS AND BALANCE REPORT	6-3
6.4 FLIGHT MASS AND CENTER OF GRAVITY	6-5
6.4.1 MOMENT ARMS	6-9
6.4.2 LOADING DIAGRAM	6-10
6.4.3 CALCULATION OF LOADING CONDITION	6-11
6.4.4 PERMISSIBLE CENTER OF GRAVITY RANGE	6-13
6.4.5 PERMISSIBLE MOMENT RANGE	6-15
6.5 EQUIPMENT LIST AND EQUIPMENT INVENTORY	6-16

6.1 INTRODUCTION

In order to achieve the performance and flight characteristics described in this Airplane Flight Manual and for safe flight operation, the airplane must be operated within the permissible mass and balance envelope.

The pilot is responsible for adhering to the permissible values for loading and center of gravity (CG). In this, he should note the movement of the CG due to fuel consumption. The permissible CG range during flight is given in Chapter 2.

The procedure for determining the flight mass CG position at any point in time is described in this Chapter. Over and above this there is a comprehensive list of the equipment approved for this airplane (Equipment List), as also a list of that equipment installed when the airplane was weighed (Equipment Inventory).

Before the airplane is delivered the empty mass and the corresponding CG position are determined, and entered in Section 6.3 - MASS AND BALANCE REPORT.

NOTE

Following equipment changes the new empty mass and the corresponding CG position must be determined by calculation or by weighing.

Following repairs or repainting the new empty mass and the corresponding CG position must be determined by weighing.

Empty mass, empty mass CG position, and the empty mass moment must be certified in the Mass and Balance Report by an authorized person.

NOTE

Refer to Section 1.6 - UNITS OF MEASUREMENT for conversion of SI units to US units and vice versa.

6.2 DATUM PLANE

The Datum Plane (DP) is a plane which is normal to the airplane's longitudinal axis and in front of the airplane as seen from the direction of flight. The airplane's longitudinal axis is parallel with the upper surface of a 600:31 wedge which is placed on top of the rear fuselage in front of the vertical stabilizer. When the upper surface of the wedge is aligned horizontally, the Datum Plane is vertical. The Datum Plane is located 2.194 meter (86.38 in) forward of the most forward point of the root rib on the stub wing.

6.3 MASS AND BALANCE REPORT

The empty mass and the corresponding CG position established before delivery are the first entries in the Mass and Balance Report. Every change in permanently installed equipment, and every repair to the airplane which affects the empty mass or the empty mass CG must be recorded in the Mass and Balance Report.

For the calculation of flight mass and corresponding CG position (or moment), the *current* empty mass and the corresponding CG position (or moment) in accordance with the Mass and Balance Report must always be used.

Condition of the airplane for establishing the empty mass:

- Equipment as per Equipment Inventory (see Section 6.5)
- Including brake fluid, lubricant (7.6 liter = 8 qts), plus unusable fuel (4 liter = approx. 1 US gal).

6.4 FLIGHT MASS AND CENTER OF GRAVITY

The following information enables you to operate your DA 40 within the permissible mass and balance limits. For the calculation of the flight mass and the corresponding CG position the following tables and diagrams are required:

- 6.4.1 - MOMENT ARMS
- 6.4.2 - LOADING DIAGRAM
- 6.4.3 - CALCULATION OF LOADING CONDITION
- 6.4.4 - PERMISSIBLE CENTER OF GRAVITY RANGE
- 6.4.5 - PERMISSIBLE MOMENT RANGE

The diagrams should be used as follows, taking the fuel tank size into account:

Empty Mass

Take the empty mass and the empty mass moment of your airplane from the Mass and Balance Report, and enter the figures in the appropriate boxes under the column marked 'Your DA 40' in Table 6.4.3 - CALCULATION OF LOADING CONDITION.

Oil

The difference between the actual amount of oil in the engine (check with dipstick) and the maximum oil quantity is called 'Oil not added'; this mass and its related moment are counted as negative. The empty mass of the airplane is established with the maximum amount of oil in the engine, thus the 'missing' oil must be subtracted. If the airplane is flown with maximum oil, the 'Oil not added' entry should be zero.

In our example 6.0 qts have been measured on the dip-stick. We are thus 2.0 qts short of the maximum, which equates to 1.9 liter. Multiplying this quantity by the mass density of 0.89 kilograms per liter gives a mass of 'Oil not added' of 1.7 kg. (in US units: 2.0 qts multiplied by the mass density of 1.86 lb/qts gives a mass of 3.7 lb).

Baggage

The DA 40 may be equipped with one of the following baggage compartment variants:

- (a) Standard baggage compartment.
- (b) Standard baggage compartment with 'baggage tube'.
- (c) Extended baggage compartment (OÄM 40-163). It consists of a forward and an aft part.

Depending on the baggage compartment variant installed in your DA 40 the following calculations must be done in Table 6.4.3 - CALCULATION OF LOADING CONDITION:

For variants (a) and (b) use row 5 of the table; row 6 is filled with '0'

For variant (c) use row 6 of the table; row 5 is filled with '0'

Fuel

a) *Standard Tank:*

The fuel quantity can be read on the fuel indicators.

NOTE

Depending on the type of fuel probes installed, the indicator can read a maximum of 15 US gal or 17 US gal (refer to Section 7.10 for details). When the fuel quantity indicator reads the maximum amount of fuel detectable, a fuel quantity up to 20 US gal can be in the fuel tank. In this case the fuel quantity must be measured with the fuel quantity measuring device (see Section 7.10 - FUEL SYSTEM).

b) Long Range Tank:

Read the fuel quantity indicated on the fuel quantity indicators.

NOTE

At an indication of 16 US gal the amount of auxiliary fuel can be determined by switching the AUX FUEL QTY switch to the respective position (LH or RH). The indicated auxiliary fuel quantity is added to the 16 US gal.

An auxiliary fuel quantity of less than 3 US gal cannot be indicated by the system. In this case the quantity must be determined by means of the fuel quantity measuring device (see Section 7.10 - FUEL SYSTEM).

CAUTION

The correct indication of the fuel quantity takes 2 minutes after actuation of the switch.

Moments

Multiply the individual masses by the moment arms quoted to obtain the moment for every item of loading, and enter these moments in the appropriate boxes in Table 6.4.3 - CALCULATION OF LOADING CONDITION.

Total Mass and CG

Add up the masses and moments in the respective columns. The CG position is calculated by dividing the total moment by the total mass (using row 7 for the condition with empty fuel tanks, and row 9 for the pre take-off condition). The resulting CG position must be within the limits.

CAUTION

For airplanes equipped with the optional Long Range Tank,
a restricted range of permitted CG positions applies.

As an illustration the total mass and the CG position are entered on Diagram 6.4.4 - PERMISSIBLE CENTER OF GRAVITY RANGE. This checks graphically that the current configuration of the airplane is within the permissible range.

Graphical Method

Diagram 6.4.2 - LOADING DIAGRAM is used to determine the moments. The masses and moments for the individual items of loading are added. Then Diagram 6.4.5 - PERMISSIBLE MOMENT RANGE is used to check whether the total moment associated with the total mass is in the admissible range.

The result found with the graphical method is however inaccurate. In doubtful cases the result must be verified using the exact method given above.

6.4.1 MOMENT ARMS

The most important lever arms aft of the Datum Plane:

- Oil : 1.00 m 39.4 in
- Front seats : 2.30 m 90.6 in
- Rear seats : 3.25 m 128.0 in
- Wing tanks (Standard & Long Range) : 2.63 m 103.5 in
- ~~Baggage in standard baggage compartment : 3.65 m 143.7 in~~
- ~~baggage in baggage tube : 4.32 m 170.1 in~~
- Baggage in extended baggage compartment
 - forward part : 3.89 m 153.1 in
 - aft part : 4.54 m 178.7 in

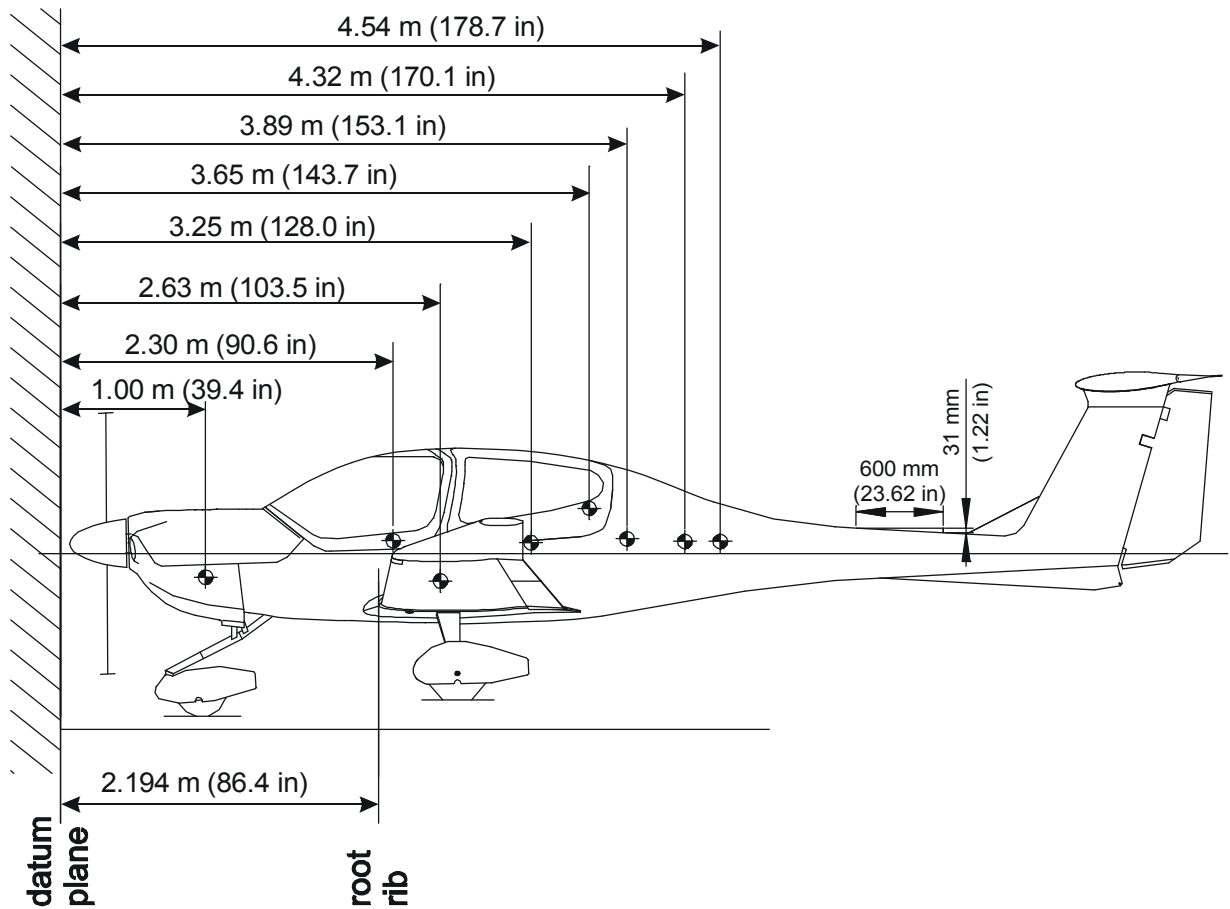

6.4.2 LOADING DIAGRAM

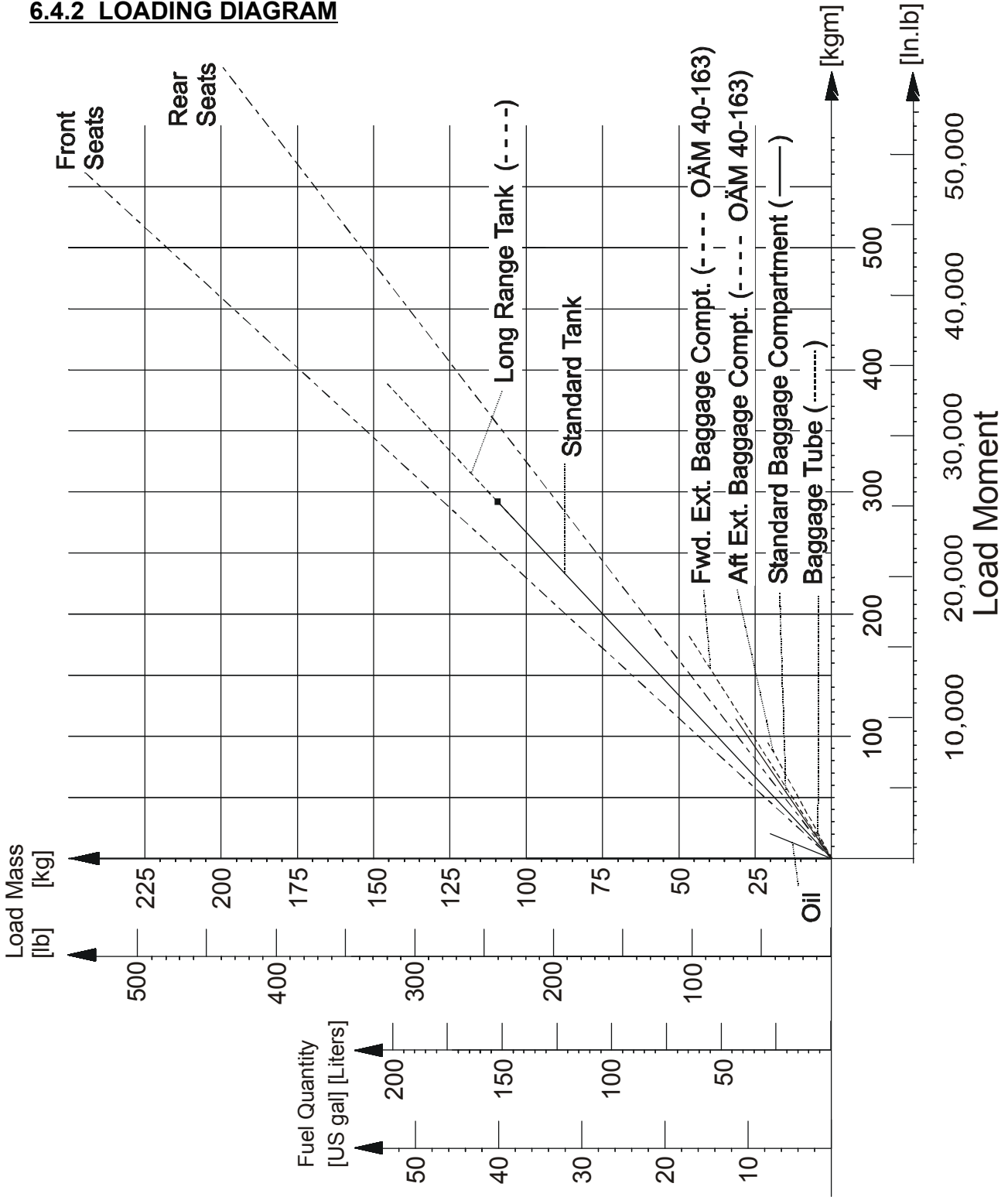

6.4.3 CALCULATION OF LOADING CONDITION**CAUTION**

For airplanes equipped with the optional Long Range Tank, a restricted range of permitted CG positions applies.

NOTE

For the mass (weight) of the fuel, a density of 0.72 kg/liter (6.01 lb/US gal) is assumed. For the mass (weight) of the engine oil, a density of 0.89 kg/liter (1.86 lb/US qt, 0.84 kg/US qt) is assumed.

NOTE

In the following example it is assumed that the fuel tank is not full at take-off.

		DA 40 (Example)		Your DA 40	
		Mass [kg] <i>[lb]</i>	Moment [kg m] <i>[in lb]</i>	Mass [kg] <i>[lb]</i>	Moment [kg m] <i>[in lb]</i>
1	Empty mass (from Mass and Balance Report)	735 <i>1620</i>	1760 <i>152,762</i>		
2	Oil not added Lever arm: 1.00 m (<i>39.4 in</i>)	-1.7 <i>-4</i>	-1.7 <i>-158</i>		
3	Front seats Lever arm: 2.30 m (<i>90.6 in</i>)	150 <i>331</i>	345 <i>29,989</i>		
4	Rear seats Lever arm: 3.25 m (<i>128.0 in</i>)	75 <i>165</i>	243.8 <i>21,120</i>		
5	Standard baggage compt. Lever arm: 3.65 m (<i>143.7 in</i>)	0 <i>0</i>	0 <i>0</i>		
	Baggage tube Lever arm: 4.32 m (<i>170.1 in</i>)	0 <i>0</i>	0 <i>0</i>		
6	Fwd. extended baggage compartment Lever arm: 3.89 m (<i>153.1 in</i>)	27 <i>60</i>	105 <i>9,186</i>		
	Aft extended baggage compartment Lever arm: 4.54 m (<i>178.7 in</i>)	18 <i>40</i>	81.7 <i>7,148</i>		
7	Total mass & total moment with empty fuel tanks (Total of 1.-6.)	1003.3 <i>2212</i>	2533.8 <i>220,047</i>		
8	Usable fuel Lever arm: 2.63 m (<i>103.5 in</i>)	99.4 <i>219</i>	261.4 <i>22,667</i>		
9	Total mass & total moment including fuel (7. plus 8.)	1102.7 <i>2431</i>	2795.2 <i>242,714</i>		
10	<p>The total moments from rows 7 and 9 (2533.8 and 2795.2 kgm) (<i>220,047 and 242,714 in.lb</i>) must be divided by the related total mass (1003.3 and 1102.7 kg respectively) (<i>2212 and 2431 lb</i>) and then located in Diagram 6.4.4 - PERMISSIBLE CENTER OF GRAVITY RANGE.</p> <p>As in our example CG positions (2.525 m and 2.535 m respectively) (<i>99.48 and 99.84 in</i>) and masses fall into the permitted area, this loading condition is allowable.</p>				

* Refer to revisions for accurate center of gravity

6.4.4 PERMISSIBLE CENTER OF GRAVITY RANGE

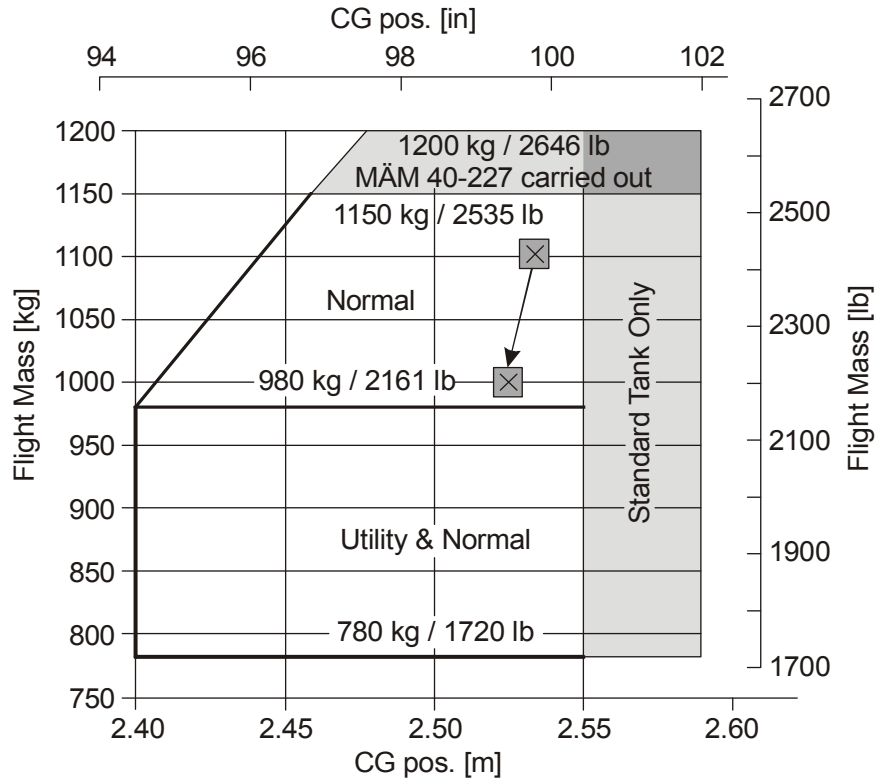

The CG's shown in the diagram are those that from the example in Table 6.4.3 - CALCULATION OF LOADING CONDITION.

Forward Flight CG Limit:

- 2.40 m (94.5 in) aft of Datum Plane at 780 to 980 kg (1720 to 2161 lb)
- 2.46 m (96.9 in) aft of Datum Plane at 1150 kg (2535 lb)
- linear variation between these values

If MAM 40-227 is carried out:

- 2.40 m (94.5 in) aft of Datum Plane at 780 kg to 980 kg (1720 lb to 2161 lb)
- 2.48 m (97.6 in) aft of Datum Plane at 1200 kg (2646 lb)
- linear variation between these values

Rearward Flight CG Limit:

2.59 m (102.0 in) aft of Datum Plane (Standard Tank)

2.55 m (100.4 in) aft of Datum Plane (with Long Range Tank installed)

* Refer to revisions for accurate moment

6.4.5 PERMISSIBLE MOMENT RANGE

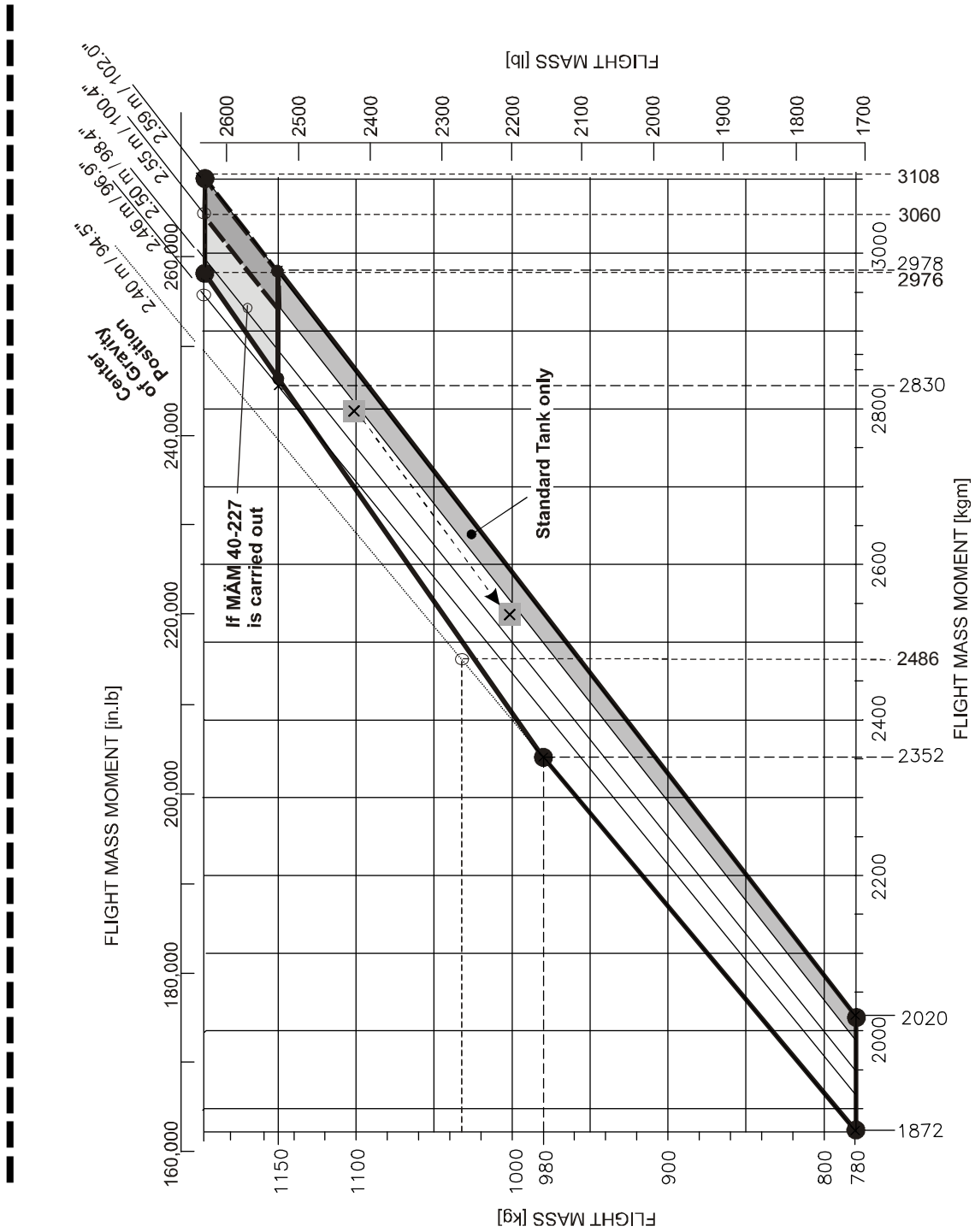

* Refer to revisions for equipment list

6.5 EQUIPMENT LIST AND EQUIPMENT INVENTORY

All equipment that is approved for installation in the DA 40 is shown in the *Equipment List* below.

The items of equipment installed in your particular airplane are indicated in the appropriate column. The set of items marked as 'installed' constitutes the *Equipment Inventory*.

NOTE

The equipment listed below cannot be installed in any arbitrary combination. The airplane manufacturer must be contacted before removing or installing equipment, with the exception of replacing a unit by an identical unit.



Mass + Lever Arm may not be exact
 - Refer to Airplane specific POH for exact numbers

Airplane Serial No.:		Registration:		Date:		Mass		Lever Arm	
Description	Type	Part No.	Manufacturer	S/N	installed	lb	kg	in	m
AVIONICS COOLING									
Cooling fan	Cyclone 21-3 Port	CRB122253	Lone Star Aviation						
Cooling fan	ACF 328	ACF 328	Sandia Aerospace						
COMMUNICATION									
COMM #1 antenna	CI 291		Comant			0.5	0.227	177.16	4.500
COMM #2 antenna	CI 292-2		Comant			0.5	0.227	161.42	4.100
COMM #1 antenna	DMC63-1/A		DM						
COMM #2 antenna	DMC63-2		DM						
COMM #1	KX 125	069-01028-1101	Bendix/King			11.46	5.2	70.08	1.78
COMM #1	KX 155A	069-01032-0201	Bendix/King			3.7	1.68	70.08	1.78
COMM #1	KX 165	069-01025-0025	Bendix/King			5.65	2.56	70.08	1.78
COMM #1	KX 165A	069-01033-0101	Bendix/King			4.0	1.81	70.08	1.78
COMM #1	KX 165A/ 8.33 khz	069-01033-0201	Bendix/King			4.0	1.81	70.08	1.78
COMM #1	GNS 430	011-00280-00	Garmin			5.1	2.31	70.08	1.78
COMM #1	GNS 430	011-00280-10	Garmin			5.1	2.31	70.08	1.78
COMM #1	GNS 530	011-00550-00	Garmin			6.8	3.08	70.08	1.78
COMM #1	GNS 530	011-00550-10	Garmin			6.8	3.08	70.08	1.78
COMM #2	KX 155A	069-01032-0201	Bendix/King			3.7	1.68	70.08	1.78
COMM #2	GNS 430	011-00280-00	Garmin			5.1	2.31	70.08	1.78



Airplane Serial No.:		Registration:		Date:		Mass		Lever Arm	
Description	Type	Part No.	Manufacturer	SIN	installed	lb	kg	in	m
COMM #2	GNS 430	011-00280-10	Garmin			5.1	2.31	70.08	1.78
Audio Panel / Marker / ICS	KMA 28	066-01176-0101	Bendix/King			1.5	0.68	70.08	1.78
Audio Panel / Marker / ICS	GMA 340	011-00401-10	Garmin			1.2	0.54	70.08	1.78
ICS	PM1000 II	11922	PS Engineering			0.75	0.34	70.08	1.78
Headset, pilot	Echelon 100		Telex						
Headset, co-pilot	Echelon 100		Telex						
Headset, LH pax	Echelon 100		Telex						
Headset, RH pax	Echelon 100		Telex						
Speaker	FRS8 / 4 Ohms		Visaton						
Handmic	100TRA	62800-001	Telex						
AUTOPILOT SYSTEM									
Autopilot system	KAP 140		Bendix/King						
Flight computer (w/o alt. preselect)	KC 140	065-00176-5402 (without MAM 40-099 or MSB 40-018)	Bendix/King			2.02	0.918	70.08	1.78
Flight computer (with alt. preselect)	KC 140	065-00176-7702 (without MAM 40-099 or MSB 40-018)	Bendix/King			2.02	0.918	70.08	1.78
Flight computer (w/o alt. preselect)	KC 140	065-00176-5403 (with MAM 40-099 or MSB 40-018)	Bendix/King			2.02	0.918	70.08	1.78



Airplane Serial No.:		Registration:			Date:		Mass		Lever Arm	
Description	Type	Part No.	Manufacturer	S/N	installed	lb	kg	in	m	
Flight computer (with alt. preselect)	KC 140	065-00176-7703 (with MAM 40-099 or MSB 40-018)	Bendix/King			2.02	0.918	70.08	1.78	
Flight computer	KC 140	065-00176-7904	Bendix/King			2.02	0.918	70.08	1.78	
Pitch servo	KS 270 C	065-00178-2500	Bendix/King			2.7	1.224	154.0	3.93	
Pitch servo mount	KM 275	065-00030-0000	Bendix/King			1.08	0.488	154.0	3.93	
Roll servo	KS 271 C	065-00179-0300	Bendix/King			2.3	1.044	120.0	3.06	
Roll servo mount	KM 275	065-00030-0000	Bendix/King			2.7	1.224	120.0	3.06	
Trim servo	KS 272 C	065-00180-3500	Bendix/King			2.22	1.005	87.2	2.21	
Trim servo mount	KM 277	065-00041-0000	Bendix/King			1.09	0.494	87.2	2.21	
Configuration module	KCM 100	071-00073-5000	Bendix/King			0.06	0.026	70.08	1.78	
Sonalert	SC	SC 628	Mallory							
Control stick		DA4-2213-12-90	Diamond							
CWS stick		031-00514-0000	Bendix/King							
AP-disc switch		031-00428-0000	Bendix/King							
Trim switch assy		200-09187-0000	Bendix/King							
ELECTRICAL POWER										
Battery	CB24-11M (G243)		Concorde (Gill)			28.0	12.7	47.0	1.19	
Battery	RG24-11M		Concorde			26.4	11.97	47.0	1.19	
Battery	RG24-15M		Concorde			29.5	13.38	47.0	1.19	



Airplane Serial No.:		Registration:		Date:		Mass		Lever Arm	
Description	Type	Part No.	Manufacturer	SIN	installed	lb	kg	in	m
Emergency battery (28 pcs.)	MN 1500 AA		Duracell			1.52	0.69	70.08	1.78
Emergency battery (Lithium)		D41-2560-93-00	Excell			0.564	0.256	66.5	1.69
Ammeter	VM1000	4010050	Vision Microsyst.						
Ammeter current sensor	VM1000	3010022	Vision Microsyst.						
Voltmeter	VM1000	4010050	Vision Microsyst.						
Voltage regulator		VR2000-28-1 (D)	Electrosyst., Inc.						
External power connector			Diamond						
Alternator	ALU-8521LS	ALU-8521LS	Electrosyst., Inc.						
DC-AC Inverter	MD 26	MD 26-28	Mid Continent						
EQUIPMENT									
Safety belt, pilot	5-01(-) Series	5-01-1C0701	Schroth			3.36	1.524	92.52	2.35
Safety belt, co-pilot	5-01(-) Series	5-01-1C5701	Schroth			3.36	1.524	92.52	2.35
Safety belt, LH pax	5-01(-) Series	5-01-1B5701	Schroth			3.0	1.36	126.7	3.22
Safety belt, RH pax	5-01(-) Series	5-01-1B0701	Schroth			3.0	1.36	126.7	3.22
Safety belt receptacle, pilot			Schroth			0.54	0.245	92.52	2.35
Safety belt receptacle, co-pilot			Schroth			0.54	0.245	92.52	2.35
Safety belt receptacle, LH pax			Schroth			0.54	0.245	126.7	3.22
Safety belt receptacle, RH pax			Schroth			0.54	0.245	126.7	3.22
EIT unit		F-01	ACK			3	1.36	173.2	4.40



Airplane Serial No.:		Registration:		Date:		Mass		Lever Arm	
Description	Type	Part No.	Manufacturer	S/N	installed	lb	kg	in	m
ELT remote switch		E0105	ACK						
ELT antenna		E0109	ACK						
ELT unit	JE2-NG	JE-1978-1NG	Jolliet			2.43	1.1	173.2	4.40
ELT remote switch		JE-1978-16	Jolliet						
ELT antenna		JE-1978-73	Jolliet						
ELT unit	ME 406	453-6603	Artex			2	0.91	173.2	4.40
ELT buzzer		452-6505	Artex						
ELT antenna	WHIP	110-773	Artex						
ELT remote switch (ACE)		453-0023	Artex						
ELT module interface		453-1101	Artex						
Winter baffle		DA4-2157-00-00	Diamond						
Armrest		DA4-5210-50-91	Diamond						
Baggage extension (OÄM 40-163)									
Baggage net (OÄM 40-163)									
Baggage tray (OÄM 40-164)									
FLIGHT CONTROLS									
Flaps control unit (instr. panel)		430550	Diamond						
Flaps actuator assy		430555	Diamond						
Stall warning horn assy	"A"	DA4-2739-10-00	Diamond						



Airplane Serial No.:		Registration:		Date:		Mass		Lever Arm	
Description	Type	Part No.	Manufacturer	SIN	installed	lb	kg	in	m
Stall warning horn assy	"B"	DA4-2739-10-00X01	Diamond						
Stall warning horn assy	"C"	DA4-2739-10-00X02	Diamond						
Stall warning horn assy	"D"	DA4-2739-10-00X03	Diamond						
Stall warning horn assy	"E"	DA4-2739-10-00X04	Diamond						
Stall warning horn assy	"F"	DA4-2739-10-00X05	Diamond						
SAFETY EQUIPMENT									
Fire extinguisher, portable		HAL 1	AIR Total			4.85	2.2	110.0	2.794
Fire extinguisher, portable ¹⁾		A 620 T	Amerex			2.43	1.1	110.0	2.794
First aid kit									
Emergency axe		G45912	Fiskars			1.23	0.558	78.74	2.00
FUEL									
Fuel qty indicator	VM1000	4010028	Vision Microsyst.						
Fuel qty sensor LH	VM1000	30100-11	Vision Microsyst.						
Fuel qty sensor RH	VM1000	30100-11	Vision Microsyst.						
Fuel qty sensor LH (auxiliary fuel)	VM1000	30100-50	Vision Microsyst.						
Fuel qty sensor RH (auxiliary fuel)	VM1000	30100-50	Vision Microsyst.						



Airplane Serial No.:		Registration:		Date:		Mass		Lever Arm	
Description	Type	Part No.	Manufacturer	S/N	installed	lb	kg	in	m
HYDRAULIC									
Master cylinder		10-54 A	Cleveland						
Parking valve		60-5D	Cleveland						
Brake assembly		30-239 B	Cleveland						
INDICATING / REC. SYSTEM									
Digital chronometer	LC-2	AT420100	Astro Tech						
Digital chronometer	Model 803		Davtron						
Flight timer		85000-12	Hobbs						
Flight timer		85094-12	Hobbs						
Annunciator panel (system)			Diamond						
Annunciator panel	WW-IDC 001		White Wire						
CO detector	Model 452-201		CO Guardian LLC						
LANDING GEAR									
LANDING GEAR STANDARD FAIRINGS									
MLG wheel fairing LH		D41-3213-91-00	Diamond Aircraft						
MLG wheel fairing RH		D41-3213-92-00	Diamond Aircraft						
NLG wheel pant shell LH		D41-3223-91-00_1	Diamond Aircraft						



Airplane Serial No.:		Registration:		Date:		Mass		Lever Arm	
Description	Type	Part No.	Manufacturer	SIN	installed	lb	kg	in	m
NLG wheel pant shell RH		D41-3223-92-00_1	Diamond Aircraft						
NLG strut fairing assy		DA4-3227-90-00	Diamond Aircraft						
<i>LANDING GEAR SPEEDKIT</i>									
MLG speed cover LH		DA4-3219-27-00_1	Diamond Aircraft						
MLG speed cover RH		DA4-3219-28-00_1	Diamond Aircraft						
MLG sheet cover LH		DA4-3219-25-00	Diamond Aircraft						
MLG sheet cover RH		DA4-3219-26-00	Diamond Aircraft						
MLG cover speed LH		DA4-3219-21-00	Diamond Aircraft						
MLG cover speed RH		DA4-3219-22-00	Diamond Aircraft						
MLG strut cover LH		DA4-3219-23-00	Diamond Aircraft						
MLG strut cover RH		DA4-3219-24-00	Diamond Aircraft						
NLG wheel pant shell LH		D41-3223-91-00_1	Diamond Aircraft						
NLG wheel pant shell RH		D41-3223-92-00_1	Diamond Aircraft						
NLG strut cover		DA4-3229-29-00	Diamond Aircraft						



Airplane Serial No.:		Registration:		Date:		Mass		Lever Arm	
Description	Type	Part No.	Manufacturer	S/N	installed	lb	kg	in	m
LANDING GEAR SMALL TIRES AND FAIRINGS or LANDING GEAR TALL MLG WITH FAIRINGS FOR SMALL TIRES									
MLG wheel fairing assy small tire LH		DA4-3215-91-00	Diamond Aircraft						
MLG wheel fairing assy small tire RH		DA4-3215-92-00	Diamond Aircraft						
NLG wheel fairing shell LH		DA4-3225-91-00	Diamond Aircraft						
NLG wheel fairing shell RH		DA4-3225-92-00	Diamond Aircraft						
Bracket assy LH MLG wheel fairing		DA4-3215-31-00	Diamond Aircraft						
Bracket assy RH MLG wheel fairing		DA4-3215-32-00	Diamond Aircraft						
Brake cover MLG wheel frame LH		DA4-3215-93-00	Diamond Aircraft						
Brake cover MLG wheel frame RH		DA4-3215-94-00	Diamond Aircraft						
NLG strut fairing assy		DA4-3227-90-00	Diamond Aircraft						



Airplane Serial No.:		Registration:		Date:		Mass		Lever Arm	
Description	Type	Part No.	Manufacturer	SIN	installed	lb	kg	in	m
LANDING GEAR SMALL TIRES AND FAIRINGS WITH MAINTENANCE ACCESS or LANDING GEAR TALL MLG WITH FAIRINGS FOR SMALL TIRES WITH MAINTENANCE ACCESS									
MLG wheel fairing assy access door LH		DA4-3215-91-00X01	Diamond Aircraft						
MLG wheel fairing assy access door RH		DA4-3215-92-00X01	Diamond Aircraft						
NLG wheel fairing shell LH		DA4-3225-91-00X01	Diamond Aircraft						
NLG wheel fairing shell RH		DA4-3225-92-00	Diamond Aircraft						
Bracket assy LH MLG wheel fairing		DA4-3215-31-00	Diamond Aircraft						
Bracket assy RH MLG wheel fairing		DA4-3215-32-00	Diamond Aircraft						
Brake cover MLG wheel frame LH		DA4-3215-93-00	Diamond Aircraft						
Brake cover MLG wheel frame RH		DA4-3215-94-00	Diamond Aircraft						
NLG strut fairing assy		DA4-3227-90-00	Diamond Aircraft						
LIGHTS									
Map / Reading light assy crew		W1461.0.010	Rivoret						
Cabin Light		W1461.0.010	Rivoret						
Instr./radio lights dimmer assy		WW-LCM-002	White Wire						



Airplane Serial No.:		Registration:		Date:		Mass		Lever Arm	
Description	Type	Part No.	Manufacturer	S/N	installed	lb	kg	in	m
Glareshield lamp assy		DA4-3311-10-01	Diamond Aircraft						
Glareshield light inverter		APVL328-8-3-L-18QF	Quantaflex						
Strobe / Pos. light assy LH	A600-PR-D-28	01-0790006-05	Whelen						
Strobe / Pos. light assy RH	A600-PG-D-28	01-0790006-07	Whelen						
Strobe / Pos. light assy LH	0R6002R	01-0771733-12	Whelen						
Strobe / Pos. light assy RH	0R6002G	01-0771733-11	Whelen						
Strobe light power supply LH/RH	A490ATS-CF-14/28	01-0770062-05	Whelen			1.592	0.722	101.0	2.566
Halogen Taxi light	70346-01	01-0770346-05	Whelen			0.28	0.13	79.920	2.030
Halogen Landing light	70346-01	01-0770346-03	Whelen			0.28	0.13	79.920	2.030
Electro luminescent lamps	Quantaflex 1600		Quantaflex						
Ballast	GENS D1,24V	37776	Newark						
Ballast	GENS D1,24V	37776	Newark						
Taxi light	HID LAMP D15	39663	Newark						
Landing light	HID LAMP D15	39663	Newark						
LED Taxi light	71125	01-0771125-23	Whelen			0.3	0.14	79.920	2.030
LED Landing light	71125	01-0771125-20	Whelen			0.3	0.14	79.920	2.030

Airplane Serial No.:		Registration:		Date:		Mass		Lever Arm	
Description	Type	Part No.	Manufacturer	SIN	installed	lb	kg	in	m
NAVIGATION									
Pitot/static probe, heated		DAI-9034-57-00	Diamond						
P/S probe HTR tail sensor		DA4-3031-01-00	Diamond						
Altimeter inHg/mbar, primary		5934PD-3	United Instruments			1.9	0.86	70.08	1.78
Altimeter inHg/mbar, primary	LUN 1128	1128-14B6	Mikrotechna			1.39	0.63	70.08	1.78
Altimeter inHg/mbar, secondary		5934PD-3	United Instruments			1.9	0.86	70.08	1.78
Altimeter inHg/mbar, secondary	LUN 1128	1128-14B6	Mikrotechna			1.39	0.63	70.08	1.78
Vertical speed indicator		7000	United Instruments			1.2	0.54	70.08	1.78
Vertical speed indicator	LUN 1144	1144-A4B4	Mikrotechna			0.9	0.4	70.08	1.78
Airspeed indicator		8025	United Instruments			0.7	0.32	70.08	1.78
Airspeed indicator	LUN 1116	1116-B4B3	Mikrotechna			0.77	0.35	70.08	1.78
Outside air temp. indication		301F(C)	Davtron			0.27	0.124	70.08	1.78
Magnetic compass		C2400L4P	Airpath			0.65	0.293	70.08	1.78
Compass system C/O	KCS 55A		Bendix/King						
Slaved gyro	KG 102 A	060-00015-0000	Bendix/King			4.3	1.95	70.08	1.78
HSI	KI 525A	066-03046-0007	Bendix/King			3.38	1.53	70.08	1.78
Slaving unit (vertical)	KA 51B	071-01242-0001	Bendix/King			0.2	0.91	70.08	1.78
Slaving unit (horizontal)	KA 51B	071-01242-06	Bendix/King			0.2	0.91	70.08	1.78
Flux valve	KMT 112	071-01052-0000	Bendix/King			0.3	0.14	101.0	2.566
Directional gyro, free	AIM2051BLD	505-0031-931	BF-Goodrich			2.6	1.18	70.08	1.78

Airplane Serial No.:		Registration:		Date:		Mass		Lever Arm	
Description	Type	Part No.	Manufacturer	S/N	installed	lb	kg	in	m
Attitude indicator	AIM1100-28L(OF)	504-0111-936	BF-Goodrich			2.20	1.0	70.08	1.78
Attitude indicator	AIM1100-28L(K(OF)	504-0111-938	BF-Goodrich			2.20	1.0	70.08	1.78
Attitude indicator	AIM1100-28L(K(2F)	504-0111-941	BF-Goodrich			2.20	1.0	70.08	1.78
Turn coordinator w/o AP pickup	1394T100-(3Z)		Mid Continent Instr.			0.822	0.373	70.08	1.78
Turn coordinator	1394T100-(12RZ)		Mid Continent Instr.			1.41	0.64	70.08	1.78
Turn coordinator	1394T100-(12RA)		Mid Continent Instr.			1.41	0.64	70.08	1.78
Turn coordinator	1394T100-(12RB)		Mid Continent Instr.			1.41	0.64	70.08	1.78
Marker antenna	CI102		Comant						
DME	KN 62A	066-01068-0004	Bendix/King			2.6	1.18	70.08	1.78
DME antenna	KA60	071-01174-0000	Bendix/King						
DME antenna	KA60	071-01591-0001	Bendix/King						
DME antenna	KA61	071-00221-0010	Bendix/King						
Transponder	KT 76A	066-1062-10	Bendix/King			0.85	0.39	70.08	1.78
Transponder	KT 76C	066-01156-0101	Bendix/King			0.2	0.09	70.08	1.78
Transponder	GTX 327	011-00490-00	Garmin			2.4	1.09	70.08	1.78
Transponder	GTX 330	011-00455-00	Garmin			3.4	1.54	70.08	1.78
XPDR antenna	KA60	071-01174-0000	Bendix/King						
XPDR antenna	KA60	071-01591-0001	Bendix/King						
XPDR antenna	KA61	071-00221-0010	Bendix/King						
Altitude digitizer		D120-P2-T	TCI						

Airplane Serial No.:		Registration:		Date:		Mass		Lever Arm	
Description	Type	Part No.	Manufacturer	SIN	installed	lb	kg	in	m
Altitude data system	SAE5-35	305154-00	Sandia Aerospace						
ADF	KR87	066-01072-0004	Bendix/King			2.9	1.32	70.08	1.78
ADF antenna	KA44B	071-01234-0000	Bendix/King						
ADF indicator	KI227	066-03063-0001	Bendix/King			0.7	0.32	70.08	1.78
ADF indicator	KI227	066-03063-00	Bendix/King			0.7	0.32	70.08	1.78
NAV antenna coupler	CI505		Comant						
NAV/GS antenna coupler	CI507		Comant			0.20	0.089	106.1	2.685
dual NAV/dual GS antenna coupler	CI 1125		Comant						
VOR/LOC/GS antenna	CI157P		Comant						
NAV/COM #1	KX 125	069-01028-1101	Bendix/King			11.46	5.2	70.08	1.78
NAV/COM #1 volt conv.	KA39	071-01041-001	Bendix/King						
NAV/COM #1	KX155A	069-01032-0201	Bendix/King			3.7	1.68	70.08	1.78
NAV/COM #1	KX 165	069-01025-0025	Bendix/King			5.65	2.56	70.08	1.78
NAV/COM #1	KX 165A	069-01033-0101	Bendix/King			4.0	1.81	70.08	1.78
NAV/COM #1	KX 165A, 8.33 kHz	069-01033-0201	Bendix/King			4.0	1.81	70.08	1.78
NAV/COM #2	KX155A	069-01032-0201	Bendix/King			3.7	1.68	70.08	1.78
NAVCOM/GPS #1	GNS 430	011-00280-00	Garmin			6.5	2.95	70.08	1.78
NAVCOM/GPS #1	GNS 430	011-00280-10	Garmin			6.5	2.95	70.08	1.78
NAVCOM/GPS #1	GNS 530	011-00550-00	Garmin			8.5	3.86	70.08	1.78
NAVCOM/GPS #1	GNS 530	011-00550-0	Garmin			8.5	3.86	70.08	1.78

Airplane Serial No.:		Registration:		Date:		Mass		Lever Arm	
Description	Type	Part No.	Manufacturer	S/N	installed	lb	kg	in	m
NAVCOM/GPS #2	GNS 430	011-00280-00	Garmin			6.5	2.95	70.08	1.78
NAVCOM/GPS #2	GNS 430	011-00280-10	Garmin			6.5	2.95	70.08	1.78
CDI, VOR/LOC #1	KI 208	066-03056-0000	Bendix/King			1	0.45	70.08	1.78
CDI, VOR/LOC #2	KI 208	066-03056-0000	Bendix/King			1	0.45	70.08	1.78
CDI, VOR/LOC/GS #1	GI 106A	013-00049-01	Garmin			1.4	0.64	70.08	1.78
CDI, VOR/LOC/GS #2	GI 106A	013-00049-01	Garmin			1.4	0.64	70.08	1.78
GPS	KLN 89 B	066-01148-0102	Bendix/King			3	1.36	70.08	1.78
GPS	KLN 94	069-01034-0101	Bendix/King			3	1.36	70.08	1.78
GPS antenna	KA 92	071-01553-0200	Bendix/King						
GPS antenna #1	GA 56	011-00134-00	Garmin						
GPS antenna #2	GA 56	011-00134-00	Garmin						
GPS annunciation unit	MD41-1488		Mid Continent						
GPS / AP switch assy	MD41-528		Mid Continent						
Multifunction display / GPS	KMD 150	066-01174-0101	Bendix/King			3.3	1.5	70.08	1.78
Stormscope	WX-500	805-11500-001	Goodrich						
Stormscope antenna	NY-163	805-10930-001	Goodrich						
Strike finder display	SF 2000	2000-009	Insight						
Strike finder sensor	SF 2000	2000-022	Insight						
TAS processor	TAS 600	70-2420-x TAS600	Avidyne/Ryan						
TAS processor	TAS 610	70-2420-x TAS610	Avidyne/Ryan						

Airplane Serial No.:		Registration:		Date:		Mass		Lever Arm	
Description	Type	Part No.	Manufacturer	SIN	installed	lb	kg	in	m
TAS processor	TAS 620	70-2420-x TAS620	Avidyne/Ryan						
Transponder coupler		70-2040	Avidyne/Ryan						
TAS antenna, top		S72-1750-31L	Sensor Systems						
TAS antenna, bottom		S72-1750-32L	Sensor Systems						
ENGINE									
ENGINE INDICATING									
Engine	IO-360-M1A		Textron Lycoming						
ENGINE FUEL CONTROL									
Fuel flow transmitter	VM1000	3010032	Vision Microsyst.						
Fuel pressure transmitter	VM1000	3010017	Vision Microsyst.						
ENGINE IGNITION SYSTEM									
SlickSTART booster	SS1001		Unison						
Lasar ignition controller	LC-1002-03	LC-1002-03	Unison						
Lasar ignition harnedd	LH-1004-43		Unison						
Magneto RH/LH	4370/4347		Slick						
Magneto RH/LH	4770/4771		Slick						



Airplane Serial No.:		Registration:		Date:		Mass		Lever Arm	
Description	Type	Part No.	Manufacturer	S/N	installed	lb	kg	in	m
RPM sensor	VM1000	3010005	Vision Microsyst.						
Manifold pressure sensor	VM1000	3010016	Vision Microsyst.						
Cyl. head temp. probes (4 each)	VM1000	1020061	Vision Microsyst.						
EGT probes	VM1000	1020060	Vision Microsyst.						
Data processing unit	DPU	4010067	Vision Microsyst.						
Data processing unit	DPU	4010081	Vision Microsyst.						
Integr. engine data display	VM1000	4010050	Vision Microsyst.						
I/O board assy		3020003	Vision Microsyst.						
I/O board assy		3020018	Vision Microsyst.						
ENGINE OIL									
Oil temperature sensor	VM1000	3010021	Vision Microsyst.						
Oil pressure transducer	VM1000	3010018	Vision Microsyst.						
ENGINE STARTING									
Starter	149-24LS		Skytec						

Airplane Serial No.:		Registration:		Date:		Mass		Lever Arm	
Description	Type	Part No.	Manufacturer	S/N	installed	lb	kg	in	m
PROPELLER SYSTEM									
Propeller	MTV-12-B/180-17		mt-Propeller			47.0	21.32	15.0	0.381
Propeller	MTV-12-B/180-17f		mt-Propeller			47.0	21.32	15.0	0.381
Propeller governor	C-210776		Woodward			3.05	1.385	29.4	0.747
Propeller governor	MT-P420-10		mt-Propeller			2.0	0.907	29.4	0.747
Propeller governor	MT-P860-23	P-860-23	mt-Propeller			2.05	0.93	29.4	0.747
AIRPLANE FLIGHT MANUAL									
			Diamond						

1) The Amerex A 620 T fire extinguisher is UL approved and can be used in airplanes registered in Canada and the USA. For airplanes registered in other countries, refer to the national Airworthiness Authority.

Place: _____

Date: _____

Signature: _____

CHAPTER 7

DESCRIPTION OF THE AIRPLANE AND ITS SYSTEMS

	Page
7.1 INTRODUCTION	7-3
7.2 AIRFRAME	7-3
7.3 FLIGHT CONTROLS	7-4
7.4 INSTRUMENT PANEL	7-10
7.5 LANDING GEAR	7-13
7.6 SEATS AND SAFETY HARNESSSES	7-15
7.7 BAGGAGE COMPARTMENT	7-17
7.8 CANOPY, REAR DOOR, AND CABIN INTERIOR	7-18
7.9 POWER PLANT	7-21
7.9.1 ENGINE, GENERAL	7-21
7.9.2 OPERATING CONTROLS	7-22
7.9.3 PROPELLER	7-25
7.9.4 ENGINE INSTRUMENTS	7-26
7.10 FUEL SYSTEM	7-32
7.11 ELECTRICAL SYSTEM	7-41
7.11.1 GENERAL	7-43
7.11.2 DAI ANNUNCIATOR PANEL(WARNING, CAUTION AND STATUS LIGHTS)	7-47
7.11.3 WHITE WIRE ANNUNCIATOR PANEL(WARNING, CAUTION AND STATUS LIGHTS)	7-50
7.12 PITOT-STATIC SYSTEM	7-55
7.13 STALL WARNING	7-55
7.14 AVIONICS	7-55

	7.15	CO-MONITOR (IF INSTALLED)	7-56
	7.15.1	SELF TEST SEQUENCE	7-56
	7.15.2	IN-FLIGHT CO ALARM	7-56
	7.15.3	UNIT FAILURE INDICATION	7-57

7.1 INTRODUCTION

Chapter 7 contains a description of the airplane and its systems, together with operating instructions.

For details about optional equipment see Chapter 9.

7.2 AIRFRAME

Fuselage

The GFRP fuselage is of semi monocoque molded construction. The fire protection on the firewall is of a special fire-resistant matting, which is covered on the engine side by stainless steel cladding. The two main bulkheads are GFRP/CFRP items.

Wings

The wings have a front and rear spar; each wing has a top shell and a bottom shell - a 'fail safe' concept. The wings, as well as the aileron and flaps, are made of GFRP/CFRP, and are principally of sandwich construction. An aluminum fuel tank is installed in each of the wings.

Empennage

The airplane has a 'T' tail of GFRP semi monocoque construction. Both the stabilizers have twin spars and a skin with no sandwich. Rudder and elevator are of sandwich construction.

7.3 FLIGHT CONTROLS

The ailerons, elevator and wing flaps are operated through control rods, while the rudder is controlled by cable. The flaps are electrically operated. Elevator forces can be balanced by a trim tab on the elevator, which is operated by a Bowden cable.

Ailerons

Construction: GFRP/CFRP composite sandwich

Hinges: There are 4 hinges, which are hinge pins mounted in an aluminum bracket. They are secured in position by a roll pin. The absence of this roll pin can lead to the loss of the hinge pin and a consequent loss of flight safety.

Operation: A rod-end bearing is screwed into a steel push rod and locked by means of a nut which has locking varnish applied to it. Damage to this varnish can indicate a twisting and thus a change to the adjustment. The connection between the rod-end bearing and the control horn is a bolt, the nut of which is likewise sealed with locking varnish.

The aluminum control horn is attached to the aileron with 3 screws.

Flaps

Construction: GFRP/CFRP composite sandwich

Hinges: There are 6 hinges, which are hinge pins mounted in an aluminum bracket. They are secured in position by a roll pin. The absence of this roll pin can lead to the loss of the hinge pin and a consequent loss of flight safety. Another aluminum fitting is located at the fuselage and is attached to a torsion tube. The torsion tube is located in the fuselage, creating a connection between the left and right flaps.

Operation: A rod-end bearing is screwed into a steel push rod and locked by means of a nut which has locking varnish applied to it. Damage to this varnish can indicate a twisting and thus a change to the adjustment. The connection between the rod-end bearing and the control horn is a bolt, the nut of which is likewise sealed with locking varnish.

The flap control horn is attached to the flap with 3 screws.

The flaps are driven by an electric motor and have 3 settings:

- Cruise (UP), totally retracted
- Take-off (T/O), and
- Landing (LDG).

The flaps are operated by means of a 3-position flap selector switch on the instrument panel. The positions of the switch correspond to the positions of the flaps, the Cruise position of the switch being at the top. If the switch is moved to another position, the flaps continue to travel automatically until they have reached the position selected on the switch. The UP and LDG positions are additionally protected by a limit switch to guard against over-running the end positions.

The electrical flap drive has an automatic circuit breaker which can also be operated manually.

Flap Position Indicator:

The current flap position is indicated by means of three lights beside the flap selector switch.

When the upper light (green) is illuminated, the flaps are in the Cruise position (UP);

When the center light (white) is illuminated, the flaps are in Take-off position (T/O);

When the lower light (white) is illuminated, the flaps are in Landing position (LDG).

When two lights are illuminated simultaneously, the flaps are between the two indicated positions. This is the case only when the flaps are traveling.

Elevator

Construction: GFRP sandwich

Hinges: 5 hinges

Operation Steel push-rods;

Two of the bellcrank bearings are accessible to visual inspection next to the lower hinge of the rudder. The elevator horn and its bearing, as well as the connection to the push-rod, can be visually inspected at the upper end of the rudder.

Rudder

Construction: GFRP sandwich

Hinges: Upper hinge: One bolt.

Lower hinge: Bearing bracket including rudder stops, held by 4 screws to the rear web of the vertical stabilizer. The mating part on the rudder is a bracket which is attached to the rudder by 2 bolts. The bolts and nuts are accessible to visual inspection.

Operation: Steel cables, the eyes of which are connected to the bolts on the bracket.

Elevator Trim

The trim control is a black wheel in the center console to the rear of the engine controls. To guard against over-rotating, the trim wheel incorporates a friction device. A mark on the wheel shows the take-off (T/O) position.

Turn wheel to the front = nose down

Turn wheel to the rear = nose up

Pedal Adjustment

NOTE

The pedals may only be adjusted on the ground!

- The pedals are unlocked by pulling the black T-grip handle, which is located behind the rear attachment, straight back .

NOTE

- When adjusting rudder pedals to install the control surfaces
- gust lock pull straight back on T-grip, do not pull up.

Forward Adjustment:

Whilst keeping the handle pulled, push the pedals forward with your feet. Release the handle and allow the pedals to lock into place.

Rearward Adjustment:

Using the unlocking handle, pull the pedals back to the desired position. Release the handle and push the pedals forward with your feet until they lock into place.

Electrical Pedal Adjustment (Optional Equipment, OAM 40-251)**NOTE**

The pedals may only be adjusted on the ground!

The pedals are adjusted using a rocker switch, located on the rear wall of the leg room.
The related circuit breaker is located below the switch.

Forward Adjustment

To move the pedals forward, depress lower side of switch. When pedals are in correct position, release switch.

Rearward Adjustment

To move the pedals in the rearward direction, depress upper side of switch. When pedals are in correct position, release switch.

Locking

Upon release the switch moves automatically to the 'power off' position, so locking the pedals in the present position.

7.4 INSTRUMENT PANEL

Instrument Panel Variants

The DA 40 can be equipped with one of numerous instrument panel variants. Therefore only two example variants (VFR and IFR) are described in this section. The equipment that is actually installed in a particular airplane is listed in the Equipment Inventory in Section 6.5. The airplane manufacturer must be contacted before removing or installing equipment, with the exception of replacing a unit by an identical unit.

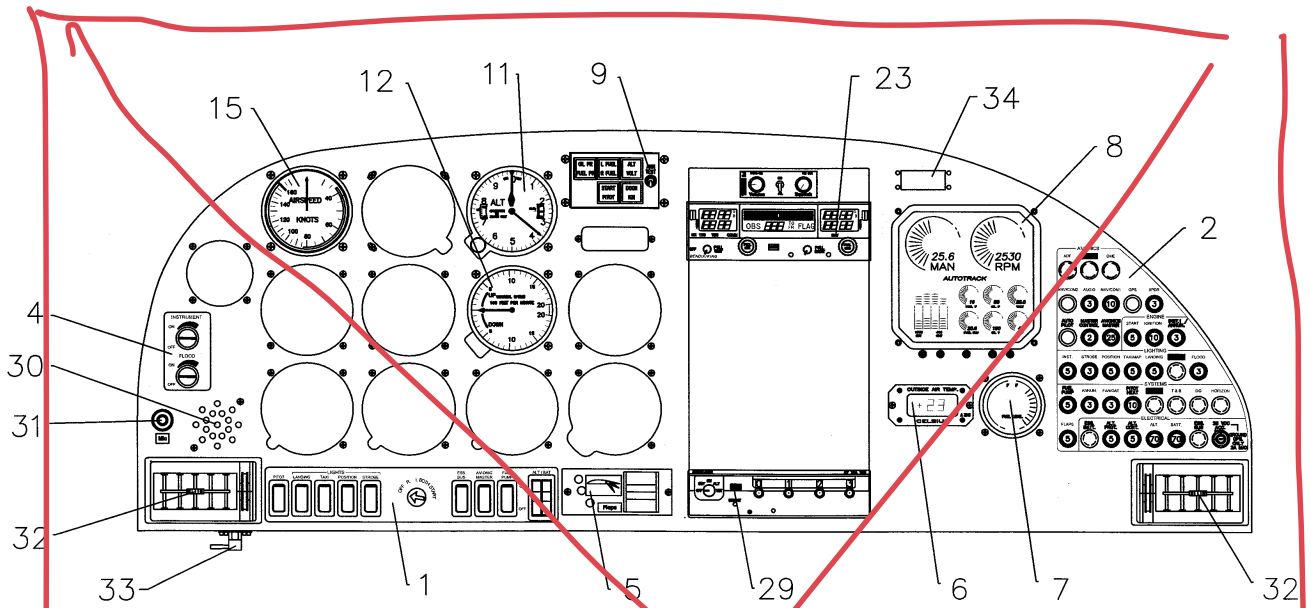

VFR instrument panel (example)

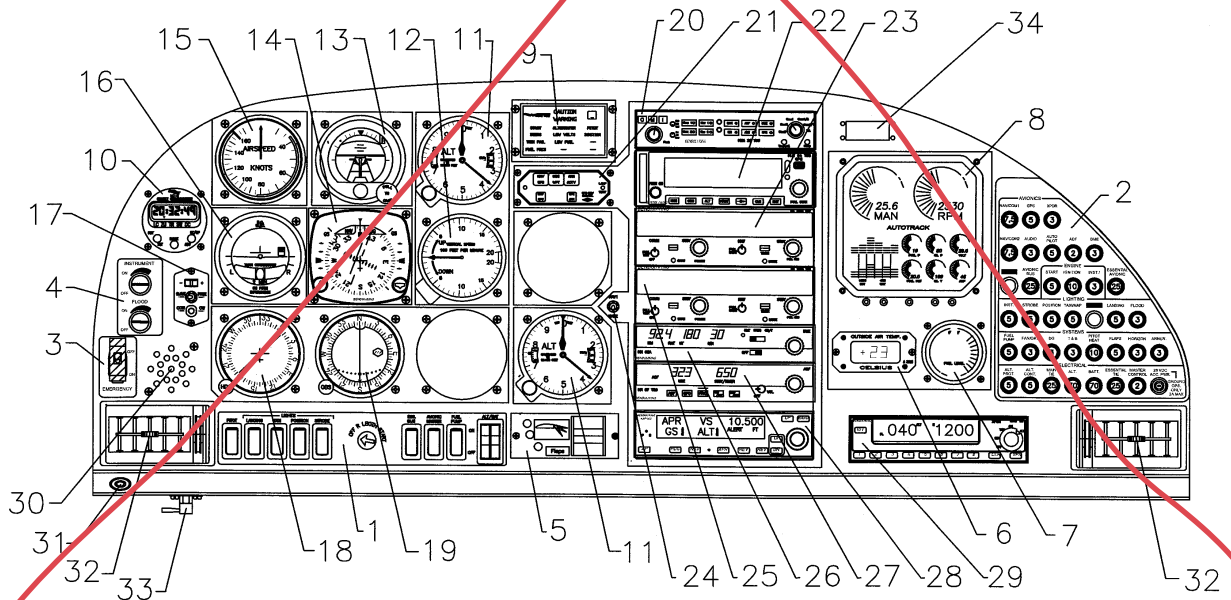

IFR instrument panel (example)

Major Instruments and Controls	
1 Electrical switches, ignition switch	18 ADF indicator
2 Circuit breakers*	19 Course deviation indicator (CDI)
3 Emergency switch	20 Audio amplifier / intercom / marker beacon receiver
4 Rotary buttons for instrument lighting and flood light	21 GPS Annunciation Control Unit
5 Flap selector switch	22 GPS
6 OAT indicator	23 Radio / VOR, No. 1
7 Fuel quantity indicator	24 Remote DME switch
8 Engine instruments	25 Radio / VOR, No. 2
9 Lights (Annunciator Panel)	26 DME
10 Chronometer	27 ADF receiver
11 Altimeter	28 Autopilot control unit (optional)
12 Vertical speed indicator (VSI)	29 Transponder
13 Attitude gyro (artificial horizon)	30 Stall warning horn
14 Horizontal situation indicator (HSI)	31 Microphone socket
15 Airspeed indicator	32 Ventilation nozzles
16 Turn & bank indicator	33 Alternate Static Valve (optional for VFR version)
17 Slaving meter	34 ELT operating unit (RCPI)

*) Designations and abbreviations used to identify the circuit breakers are explained in Section 1.5 - DEFINITIONS AND ABBREVIATIONS.

Cockpit Ventilation

Ventilation in the front is provided by the movable ventilation nozzles (17) in the instrument panel. Furthermore there are spherical nozzles in the roll bar on the left and right side next to the front seats as well as on the central console above the passengers' heads. The spherical nozzles are opened and closed by twisting.

7.5 LANDING GEAR

The landing gear consists of a main landing gear of sprung steel struts, and a free-castering nose wheel which is sprung by an elastomer package.

The wheel fairings are removable. When flying without wheel fairings, it should be noted that there is a reduction in some areas of performance (see Chapter 5).

Wheel Brakes

Hydraulically operating disk brakes act on the wheels of the main landing gear. The wheel brakes are individually operated by means of toe pedals.

Parking Brake

The lever is located on the small center console under the instrument panel, and is in the upper position when the brakes are released. To operate the parking brake pull the lever downwards until it catches. Brake pressure is built up by multiple operation of the toe brake pedals, and is maintained until the parking brake is released. To release, the lever is pushed upwards.

Hydraulic System Schematic

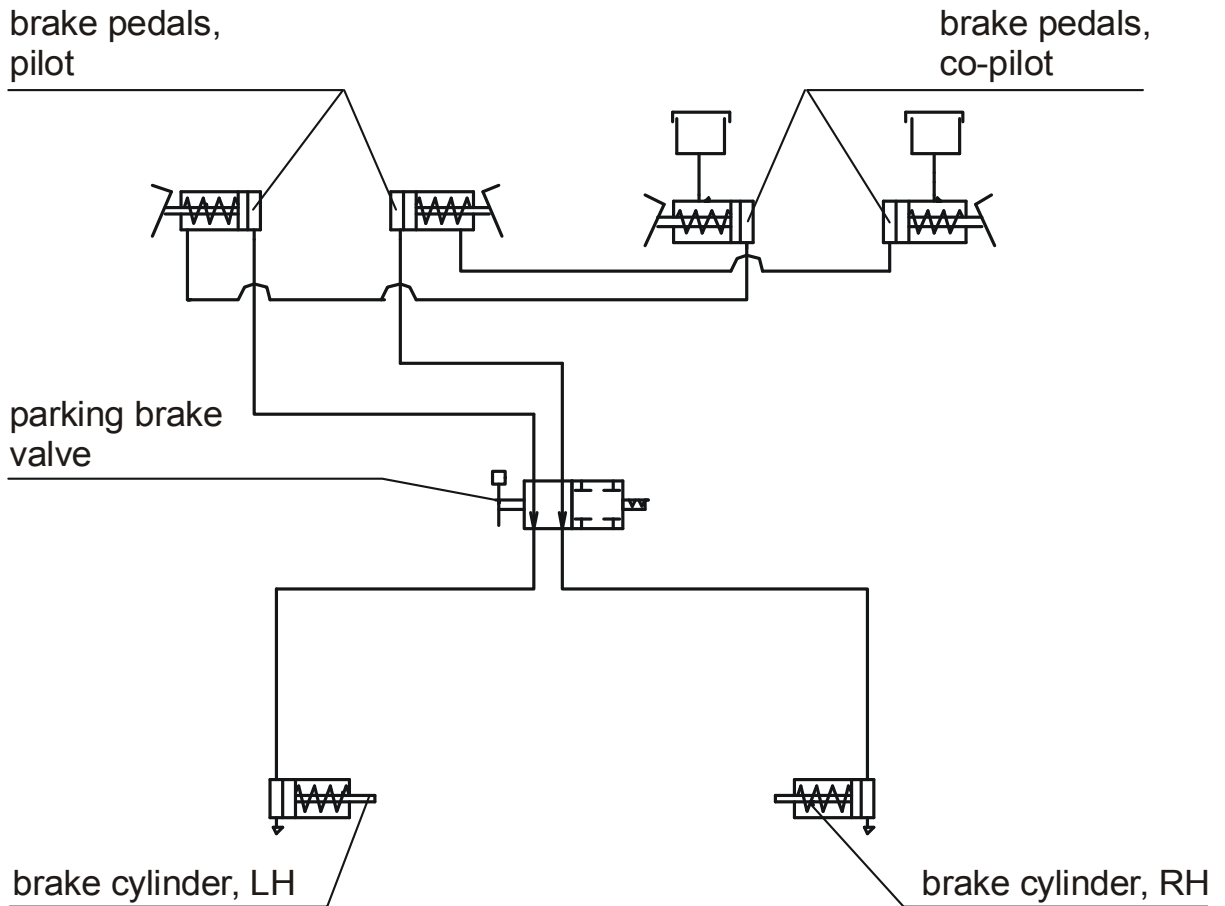

7.6 SEATS AND SAFETY HARNESSSES

To increase passive safety, the seats are constructed using a carbon fiber/Kevlar hybrid material and GFRP. The seats are removable to facilitate the maintenance and inspection of the underlying controls. Covers on the control sticks prevent loose objects from falling into the area of the controls.

- If front seats with adjustable backrests are installed (OÄM 40-252), the angle of the backrests can be adjusted for best comfort. The backrest lever is situated on the outboard side of the backrest. However, during take-off, landing and emergency landing the backrests must be fixed in the upright position designated by a placard on the roll-over bar.

CAUTION

- Before the backrest lever is lifted in order to unlock the backrest, lean back towards the backrest to counteract the spring load; otherwise the backrest may snap forward.
- For adjustment lift the backrest lever and bend forward or backward to the desired backrest angle. Then release and press down the backrest lever.
- In case of a defective adjustment mechanism the outboard friction adjustment screw can be tightened with a 10 mm hexagon nut in clockwise direction in order to fix the backrest in the upright position.
- If possible, set the backrest lever to the „locked" position. The mechanism must be repaired at the next scheduled inspection.
- The lumbar support can be adjusted by operating the lumbar support lever mounted on the outboard side of the seat pan.

The seats have removable furnishings and are equipped with energy-absorbing foam elements.

The seats are fitted with three-point safety harnesses. The harnesses are fastened by inserting the end of the belts in the belt lock, and are opened by pressing the release on the belt lock.

The backs of the rear seats can be laid forward after pulling upwards on the knob of the locking bolt.

If seats with adjustable backrests are installed (OÄM-40-252):

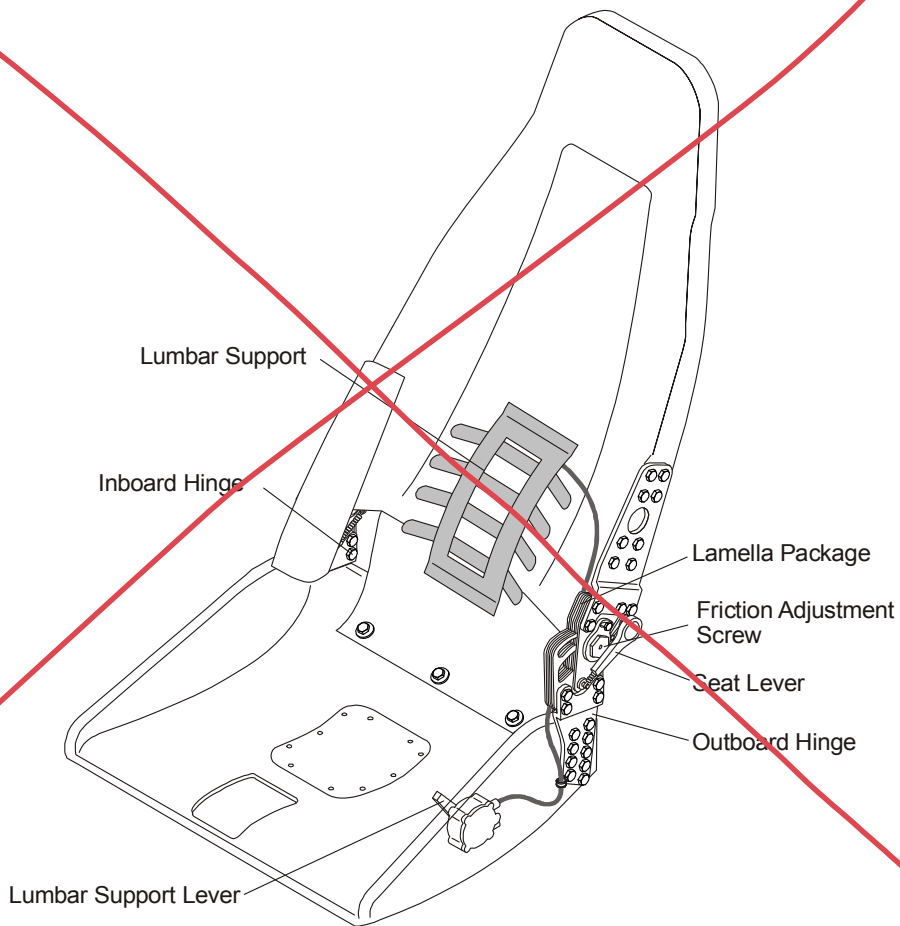

7.7 BAGGAGE COMPARTMENT

The DA 40 may be equipped with one of the following baggage compartment variants:

- (a) Standard baggage compartment.
- (b) Standard baggage compartment with 'baggage tube'.
- (c) Extended baggage compartment (OÄM 40-163). It consists of a forward and an aft part.

Without a baggage net, no baggage may be loaded.

Standard Baggage Compartment

The baggage compartment is located behind the rear seats.

Baggage Tube (if installed)

On the back side of the standard baggage compartment the baggage tube may be installed. It is separated by a cloth cover.

Extended Baggage Compartment (OÄM 40-163 and OÄM 40-164, if installed)

The extended baggage compartment consists of the standard baggage compartment behind the rear seats and the baggage extension mounted between the baggage compartment frame and ring frame No. 1.

The baggage extension has a door that may be hinged up to keep items from sliding aft or hinged down to carry long items.

The baggage tray may be installed in the bottom of the standard baggage compartment. The lid of the baggage tray and the bottom of the baggage extension form a flat loading surface. The lid has mounting provisions for the tow bar. The space under the lid may be used to carry small items such as the gust lock and the fuel quantity measuring device.

7.8 CANOPY, REAR DOOR, AND CABIN INTERIOR

Front Canopy

The front canopy is closed by pulling down on the canopy frame, following which it is locked by means of a handle on the left hand side of the frame. On locking, steel bolts lock into mating holes in polyethylene blocks.

“Cooling gap” position: A second setting allows the bolts to lock in, leaving a gap under the front canopy.

The front canopy can be blocked by a locking device (optional) on the left side near the canopy opening lever by turning the key clockwise. The closed and blocked canopy can be opened from inside by pulling the lever inside the opening handle.

WARNING

The airplane may be operated with the front canopy in the “cooling gap” position on the ground only. Before take-off the front canopy must be completely closed and locked, but not blocked with the locking device.

A window on the left hand side of the canopy can be opened for additional ventilation or as an emergency window. Some serial numbers have another window on the right hand side of the canopy.

Emergency Axe

If OÄM 40-326 is incorporated an emergency axe is installed on the floor panel under the pilot's seat (see Figure below).

If the canopy can not be opened in case of an emergency use the emergency axe to break through the canopy.

WARNING

Make sure not to harm other persons by using the emergency axe.

WARNING

Beware of sharp edges and fragments of the broken canopy.

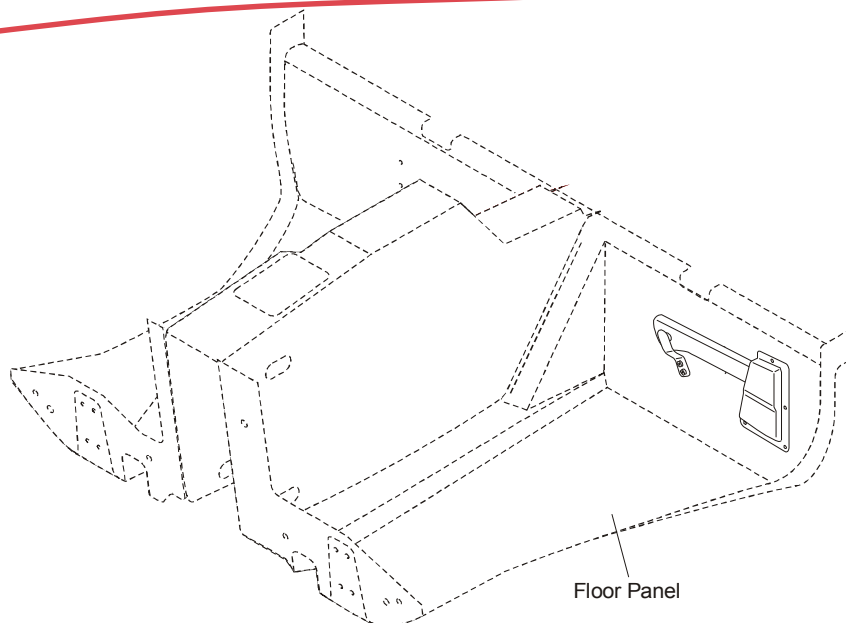

7.9 POWER PLANT

7.9.1 ENGINE, GENERAL

Lycoming IO-360-M1A: Air-cooled four-cylinder four-stroke engine. Horizontally-opposed direct-drive engine with fuel injection and underslung exhaust.

Displacement: 5916 cm³ (361 in³).

Max. power: 180 HP (134.2 kW) at 2700 RPM at sea level and ISA.

Max. continuous power: 160 HP (119.3 kW) at 2400 RPM at sea level and ISA.

The principal engine accessories at the front of the engine are the propeller governor, the starter motor, and the alternator. The ignition (optionally controlled by an electronic control unit), the twin magneto system and the mechanical fuel pump are at the rear of the engine. Fuel is supplied via a fuel injection system.

Further information should be obtained from the engine operating manual.

The engine instruments are on the right hand side of the instrument panel.

The ignition switch is designed as a key-operated lock. The ignition is switched on by moving the switch to the right from the OFF position to the L-R-BOTH positions. A further turn to the right to the START position will operate the starter motor.

7.9.2 OPERATING CONTROLS

The engine performance is controlled by means of three levers: throttle, RPM lever and mixture control lever, situated together as a group on the large center console (also referred to as the throttle quadrant). Front and rear are defined in relation to the direction of flight.

Throttle

- Left hand lever with large, black knob.

This lever is used to set the manifold pressure (MP). When the throttle is furthest forward, the engine is being provided with extra fuel for high performance settings.

Lever forward (MAX PWR) = Full throttle, higher MP

Lever to rear (IDLE) = Idle, low MP

High manifold pressure means that a large quantity of fuel-air mixture is being supplied to the engine, while low manifold pressure means a lesser quantity of fuel-air mixture is being supplied.

RPM Lever

- Central lever with blue handle.

Lever forward (HIGH RPM) = High RPM, fine pitch

Lever to rear (LOW RPM) = Low RPM, coarse pitch

By means of this lever the propeller governor controls the propeller pitch and thus engine RPM (= propeller RPM). A selected RPM is held constant by the governor independent of the airspeed and the throttle setting ('Constant Speed').

The propeller governor is flanged onto the front of the engine. It regulates the supply of engine oil to the propeller. The propeller governor oil circulation is an integral part of the engine oil circulation system. Following a defect in governor or oil system, the blades go the finest possible pitch (maximum RPM), thus allowing continuation of the flight.

CAUTION

Following failure of the governor or a serious drop in oil pressure, the RPM should be adjusted using the throttle. Every effort should be made not to exceed 2700 RPM.

CAUTION

The throttle and RPM lever should be moved slowly, in order to avoid over-speeding and excessively rapid RPM changes. The light wooden propeller blades produce more rapid RPM changes than metal blades.

Mixture Control Lever

- Right hand lever with red handle and lock to avoid inadvertent operation.

This lever is used to set the proportions in the fuel-air mixture which is supplied to the engine.

Lever forward (RICH) = Mixture rich (in fuel)

Lever to rear (LEAN) = Mixture lean (in fuel)

If the lever is at the forward stop, extra fuel is being supplied to the engine which at higher performance settings contributes to engine cooling.

In cruise, the mixture should be made leaner in order to reach the appropriate fuel-air mixture. The leaning procedure is given in Chapter 4.

To shut off the engine the mixture control lever is pulled to the rear stop. Air without fuel is thus drawn into the cylinders and the engine dies. When the engine is stationary there is thus no fuel in the cylinders.

Alternate Air

In the event of the loss of manifold pressure because of icing or blocking of the air filter, there is the possibility of drawing air from the engine compartment. The operating lever for alternate air is located under the instrument panel to the left of the center console. To open alternate air the lever is pulled to the rear. Normally, alternate air is closed, with the lever in the forward position.

Placard on the lever, forward position:

ALTERNATE AIR

Placard on the lever, visible when lever is in the rearward position:

**ALTERNATE AIR
ON**

7.9.3 PROPELLER

A mt-Propeller MTV-12-B/180-17 type or MTV-12-B/180-17f type, hydraulically-regulated 3-bladed constant speed propeller is installed. It has wood-composite blades with fiber-reinforced plastic coating and stainless steel edge cladding; in the region of the propeller hub the leading edge is coated with adhesive PU foil. These blades combine the lowest weight whilst minimizing the chance of vibration.

CAUTION

Operation on the ground at high RPM should be avoided as far as possible, as the blades could suffer stone damage. For this reason a suitable site for engine runs (magneto and propeller checks) should be selected, where there are no loose stones or similar items.

WARNING

Never move the propeller by hand while the ignition is switched ON, as it may result in serious personal injury.

Never try to start the engine by hand.

Governor

One of the following governors may be installed:

Woodward C-210776 Governor, MT P-420-10 Governor (OÄM 40-077) or MT P-860-23 Governor (OÄM 40-289).

7.9.4 ENGINE INSTRUMENTS

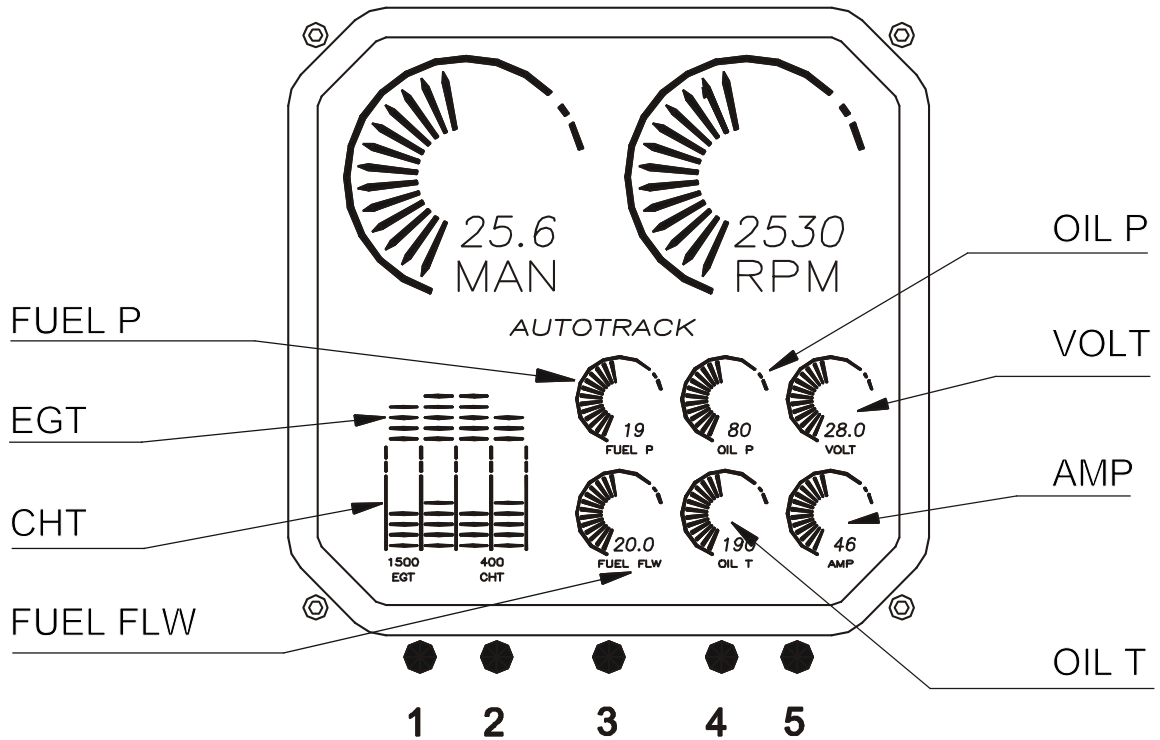

Button 1: Lean mode

Button 2: Digital exhaust gas / cylinder head temperature mode

Button 3: Switch in autotrack

Button 4: Fuel computer mode

Button 5: Engine data recorder

Button 3 has an additional function on switch-on: Display mode

Sweep Mode or Pointer Mode

If the switch-on button 3 is kept pressed until the display transfers from activating all bars/pointers to indicating the actual values, the type of presentation can be selected. In one case the circular instruments show the values with a pointer as in conventional analog instruments, whilst in the other case the circular instruments fill with pointers/bars up to the current value. It remains for the pilot to select his preferred presentation.

Indications on the Vision Microsystems VM 1000 Engine Instrument

Designation	Indication	Unit
MAN	Manifold pressure	inHg
RPM	RPM	RPM
EGT	Exhaust gas temperature	°F
CHT	Cylinder head temperature	°F
FUEL P	Fuel pressure	PSI
FUEL FLW	Fuel flow	US gal/hr
OIL P	Oil pressure	PSI
OIL T	Oil temperature	°F
VOLT	Voltage	V
AMP	Intensity of current	A

Button 1 - Lean Mode

Upon powering up the unit the Normal mode is shown. Between the colored sector markings the cylinder head temperatures of the individual cylinders are shown by bars. Above those are bars showing the exhaust gas temperatures of the individual cylinders.

In the event of the failure of a sensor the relevant indication remains empty. A flashing cylinder head temperature indication means either that the cylinder is too hot, or that it is being cooled too rapidly (shock-cooling).

The operation of button 1 causes the display to move to Lean mode. This is confirmed by two half-bars appearing to the left and right of the bar blocks. In this mode all bars which previously showed cylinder head and exhaust gas temperature are used for exhaust gas temperature only. One bar represents 10 °F (4.6 °C). If the columns are completely filled with bars before the mixture is lean, button 1 should be pressed twice so that the bars start again at the base of the indicator.

A flashing bar column indicates that the relevant cylinder has reached the hottest exhaust gas temperature. This point will be marked with a single bar, which can be used as a reference for enriching the mixture. As an option, the numerical indication can be used additionally for this purpose.

Button 2: Digital Exhaust Gas / Cylinder Head Temperature Mode

Using this button, the numerical indication for exhaust gas and cylinder head temperature underneath the graphical representation of these figures is set. Following each sequential operation of the button the exhaust gas and cylinder head temperatures of an individual cylinder are displayed. In this, the display jumps automatically from the number of the current cylinder to its current temperature. After the fourth cylinder the display switches to the Automatic mode, which gives both the number of the cylinder with the highest exhaust gas temperature as well as (beside it) the number of the hottest cylinder. Alternating with this, the associated temperatures are displayed.

Button 3: Switch in Autotrack

In the Autotrack mode changes in the engine values are shown. If button 3 is operated in flight, variations from the current values will be displayed, in that the relevant circular instrument and the annotation AUTOTRACK will start to flash.

In order to leave the mode, button 3 must be operated. The mode is left automatically if there is a critical value to be indicated.

Button 4 - Fuel Computer Mode

By operating button 4 the display is switched from fuel flow (FUEL FLW) to a numerical indication underneath it. There are 4 modes, which are called up by pressing button 4 in sequence. The modes are:

REM: The remaining fuel is shown is US gal. The steps in this are 0.1 US gal. This mode is only available if the ADD mode - add up fuel - has previously been activated.

HRS: This mode shows the remaining flight time (in hours) on the basis of the current fuel flow. The steps in this indication are tenths of hours. This mode is also only available if the ADD mode - add up fuel - has previously been activated.

BRN: This mode shows the amount of fuel used (in US gal) since the equipment was switched on. The steps in this are 0.1 US gal.

ADD: This mode can be used after refueling to bring the fuel quantity, which the equipment uses for its calculations, up to date. In order to utilize the REM and HRS modes, the computer needs to be told how much fuel has been taken on. 10 US gal are added by pressing button 3, while pressing button 5 adds one US gal to the total. The quantity is confirmed by pressing button 4. In doing this, the quantity which has been entered in ADD is added to the previous total under REM. To check the fuel quantity button 4 should be pressed until REM is shown.

If too much has been added, button 4 should not be pressed for confirmation. After approx. 20 seconds the computer automatically leaves the ADD mode.

CAUTION

Incorrect use of the computer in the fuel-computer mode will result in false statements in the "REM - remaining fuel" and the "HRS - remaining flight time" modes. Before using the fuel computer mode in flight the pilot must be certain that he has understood the operation and use of the equipment. Beyond this, use of the fuel computer must not be regarded as a substitute for fuel planning for a flight.

Button 5 - Engine Data Recorder

Operating button 5 will activate the engine data recorder. The digital values shown are the minimum values recorded by the engine instrument unit during operation, such as lowest voltage, lowest fuel pressure, etc. The numerical RPM indicator will indicate the total operating hours.

Pressing button 5 again will show the maximum values encountered. Pressing button 5 still another time will turn off the engine data recorder and the display will return to the original mode. If button 5 is not pressed for approximately 20 seconds, the display will automatically return to the original mode.

Data of the engine data recorder can be called during or immediately after flight only. With each new flight the old data will be overwritten.

7.10 FUEL SYSTEM

a) Standard Tank:

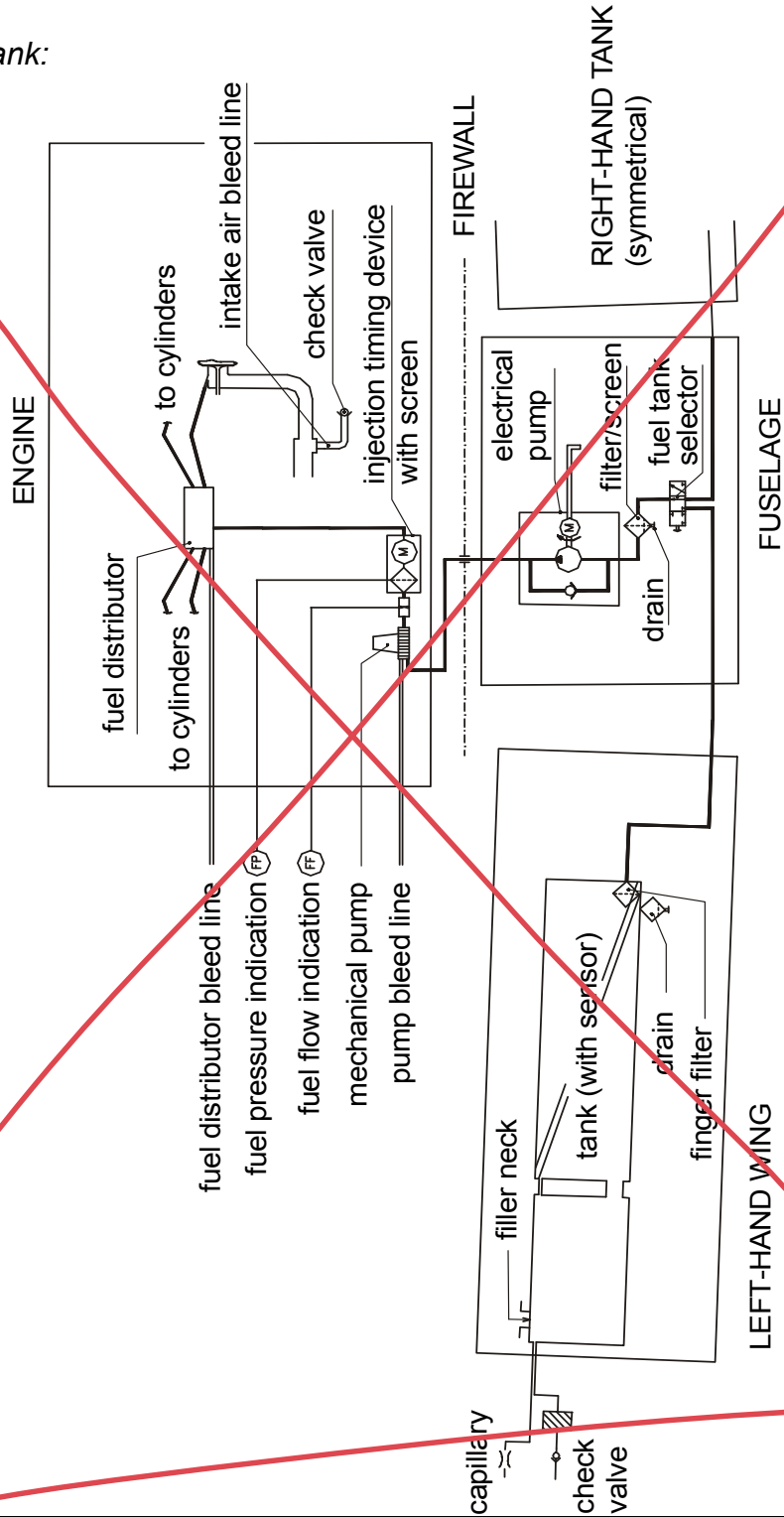

b) Long Range Tank:

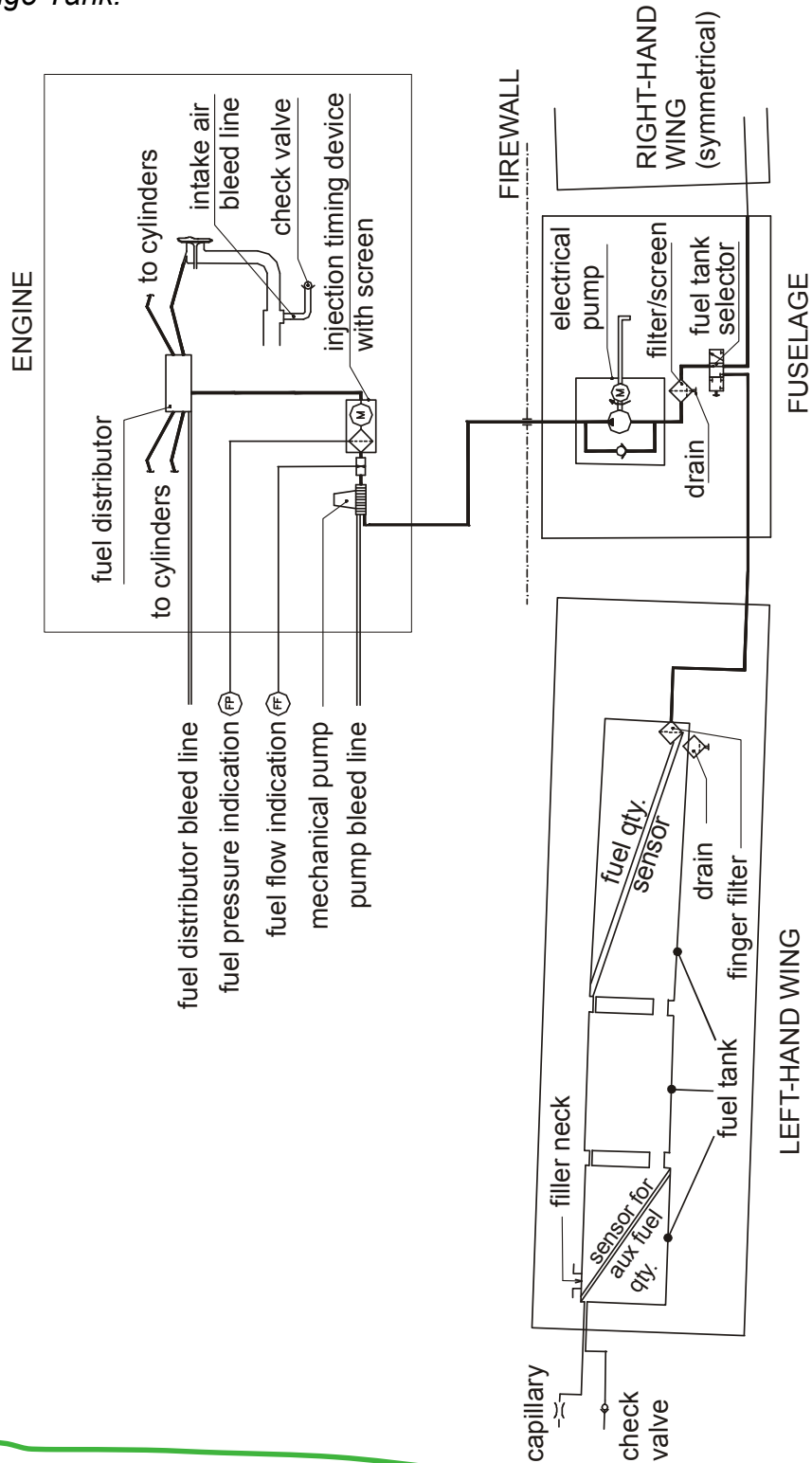

Fuel Pumps

The fuel system is equipped with a mechanical and an electrical fuel pump. The mechanical pump provides for the normal fuel supply.

The electrical fuel pump is provided as an auxiliary and emergency pump, which does not operate under normal circumstances. It is operated with the FUEL PUMP switch on the row of switches on the instrument panel. It is checked during engine start, and is used as a safety back-up during take-off and landing, as well as when switching fuel tanks. It is also switched on for safety in the event of a decrease in fuel pressure.

Fuel Tank Selector

The fuel tank selector is situated on the center console. Its positions are LEFT (tank), RIGHT (tank) and OFF. The OFF position is reached by turning the selector to the right while pulling up the safety catch of the fuel tank selector. This is to ensure that an OFF selection is not made unintentionally.

a) *Standard Tank*

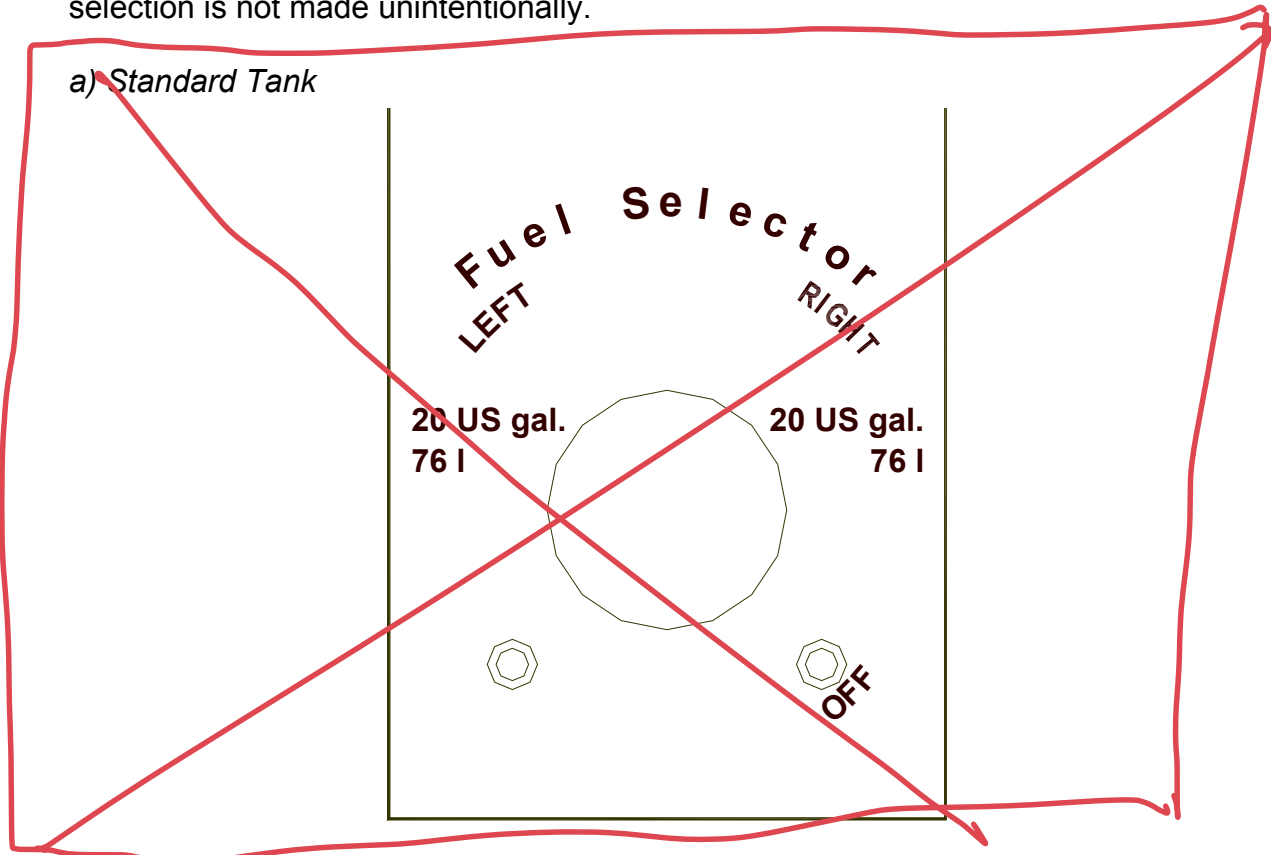

b) Long Range Tank

Plane says:
 24 US gal
 91 l

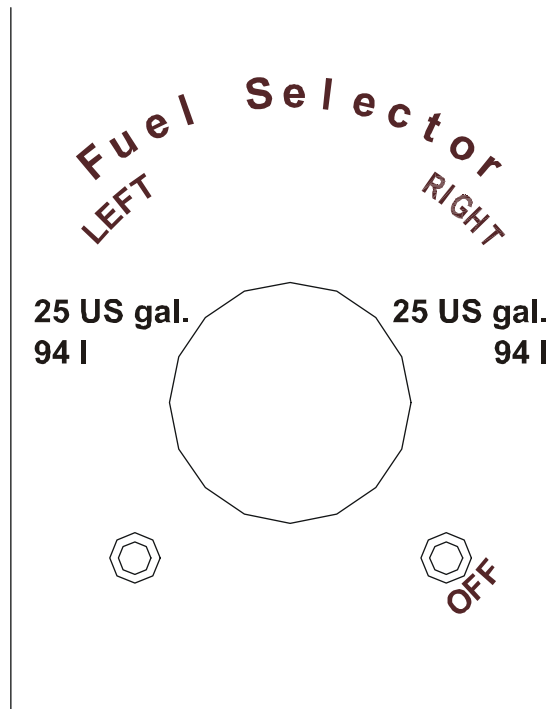
Fuel Tanks

Each of the two wing tanks consists of two (standard tank) or three (long range tank) aluminum chambers which are joined by a piece of flexible hose and two independent vent hoses. There are two separate vents per tank. The hose terminations are situated on the underside of the wing, approx. 2 meter (7 ft) from the wing tip. One vent acts as a capillary, both to equalize the air pressure, and to provide a safety factor in the event of a failure of the other vent. The second vent is a check valve, to allow air to enter the tank, but prevent flow to the outside.

A coarse filter (finger filter) is fitted before the outlet. To allow draining of the tank, there is an outlet valve at its lowest point. A gascolator sits at the lowest point in the fuel system. A drain valve is fitted to the gascolator, which can be used to remove water and sediment which has collected in the fuel system. This valve is fitted centrally on the underside of the fuselage, approximately 30 cm (1 ft) forward of the wing leading edge.

Fuel Quantity Indication

a) Standard Tank

A capacity probe ascertains fuel quantity in the tank. When the fuel quantity indicator reads zero, only the unusable fuel remains in the tank. The total capacity of each tank is 20 US gal (approximately 76 liter). The maximum quantity that can be indicated is either 15 US gal (up to serial number 40.054) or 17 US gal (serial number 40.055 and subsequent). The indication up to this quantity is correct. At an actual quantity above 15 US gal / 17 US gal the indication remains at 15 US gal / 17 US gal.

NOTE

When the fuel quantity indicator reads 15 US gal / 17 US gal, the correct fuel quantity must be determined with the fuel quantity measuring device. If this measurement is not carried out, the fuel quantity available for flight planning is 15 US gal / 17 US gal.

b) Long Range Tank

For ascertaining fuel quantity in the enlarged tanks an additional capacitive probe is used on each side (LH/RH). When the fuel quantity indicator reads zero, only the unusable fuel remains in the tank. The usable capacity of each tank is 25 US gal (approximately 94 liter).

Up to an actual fuel quantity of 16 US gal the fuel quantity is measured by the standard probes and is brought to indication on the left and right side of the instrument in increments of 1 US gal.

A fuel quantity between 16 US gal and 25 US gal is ascertained by the additional probes and is brought to indication in the central area of the fuel quantity indicator. The indication is numerical in 3 US gal steps (in the range from 0 to 3 US gal) and 1 US gal steps (in the range above 3 US gal up to max. 9 US gal). The side to be indicated can be selected by the AUX FUEL QTY switch (see figure below) which is located next to the indicator. The indication on the left and right side of the instrument (0 US gal to max. 16 US gal) is not affected by the switch.



The actual fuel quantity in the respective tank (LH/RH) is the sum of the central indication and the corresponding indication on the left or right side.

CAUTION

The correct indication of the fuel quantity takes 2 minutes after actuation of the AUX FUEL QTY switch.

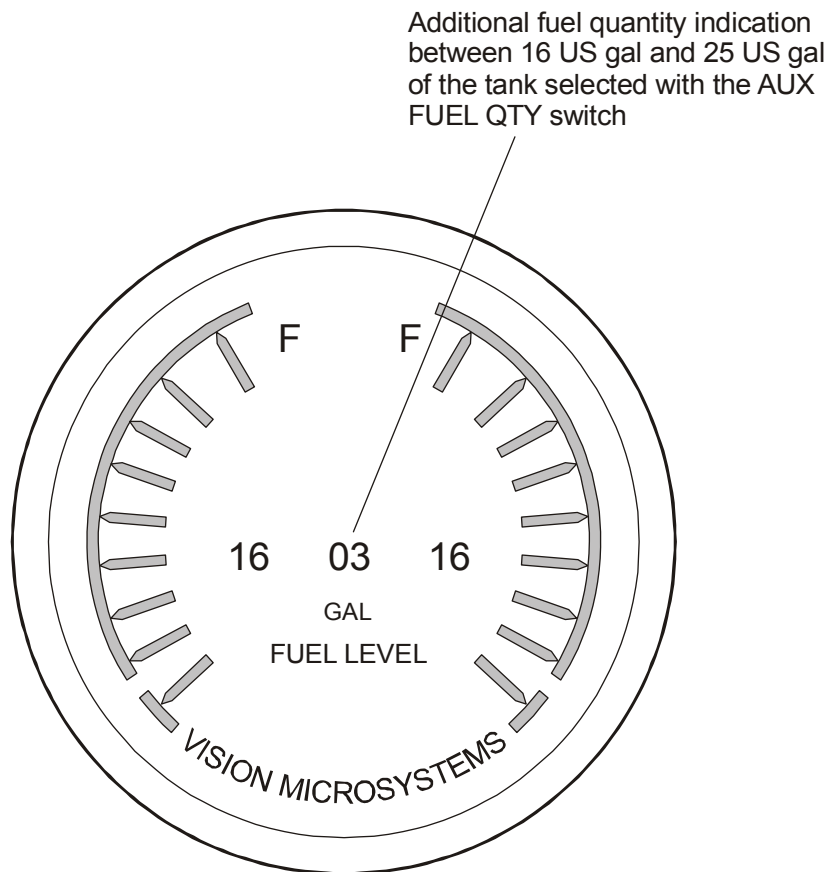

Fuel Quantity Measuring Device

The fuel quantity measuring device allows the fuel quantity in the tank to be determined during the pre-flight inspection. It functions according to the principle of communicating containers. The fuel quantity measuring device has a recess which fits the airfoil of the wing. With this recess the device is held against the stall strip at the leading edge of the wing. The exact position is marked by a bore in the stall strip. Then the metal connector is pressed against the drain of the tank. The amount of fuel in the tank can now be read off from the vertical ascending pipe.

For a correct indication the airplane must be placed on a horizontal ground and the fuel filler must have been opened before.

The designated place for the fuel quantity measuring device is the bag on the rear side of the pilot's seat.

CAUTION

Different fuel measuring devices are used for the standard tank and the long range tank. The use of the wrong device results in a wrong indication.

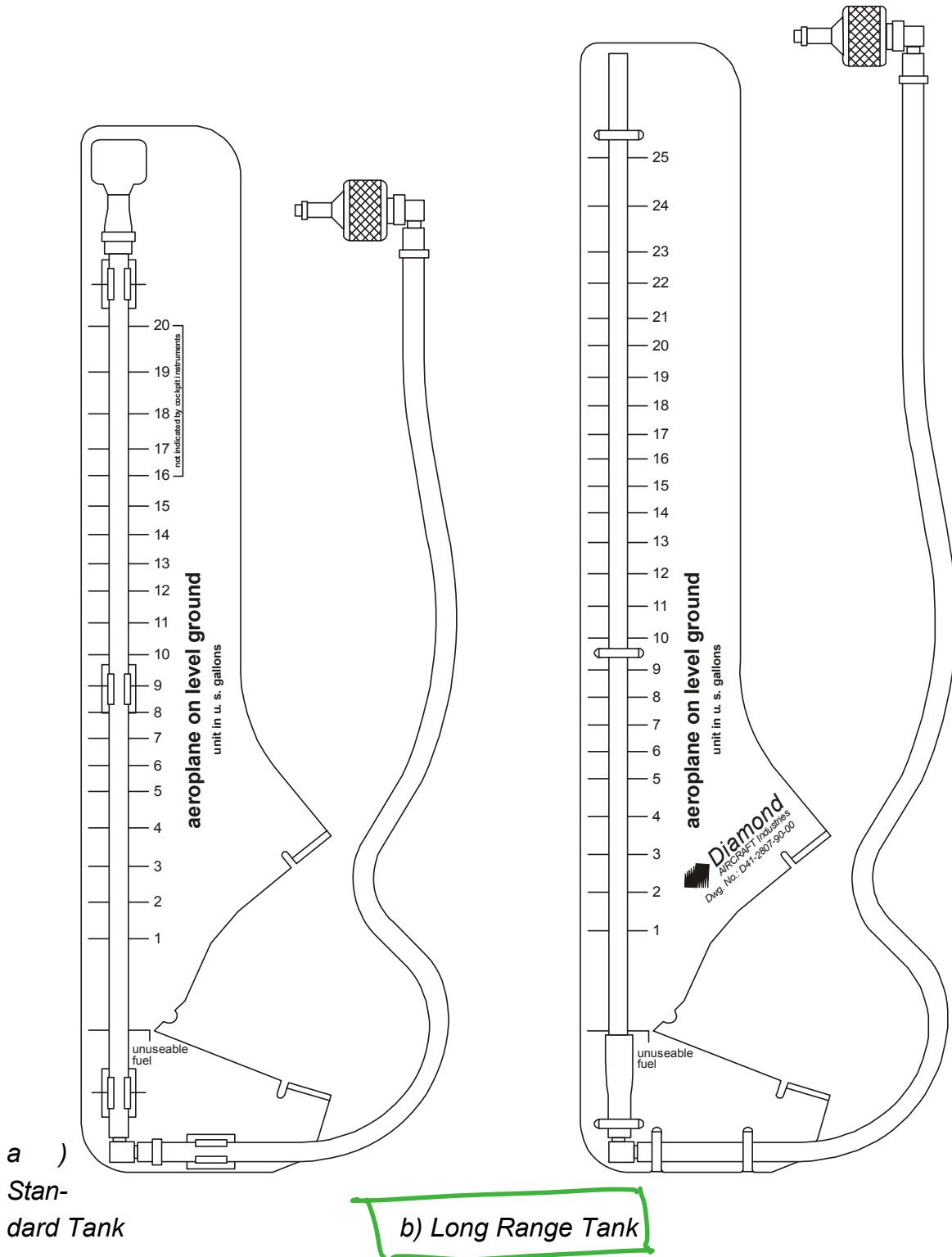

7.11 ELECTRICAL SYSTEM

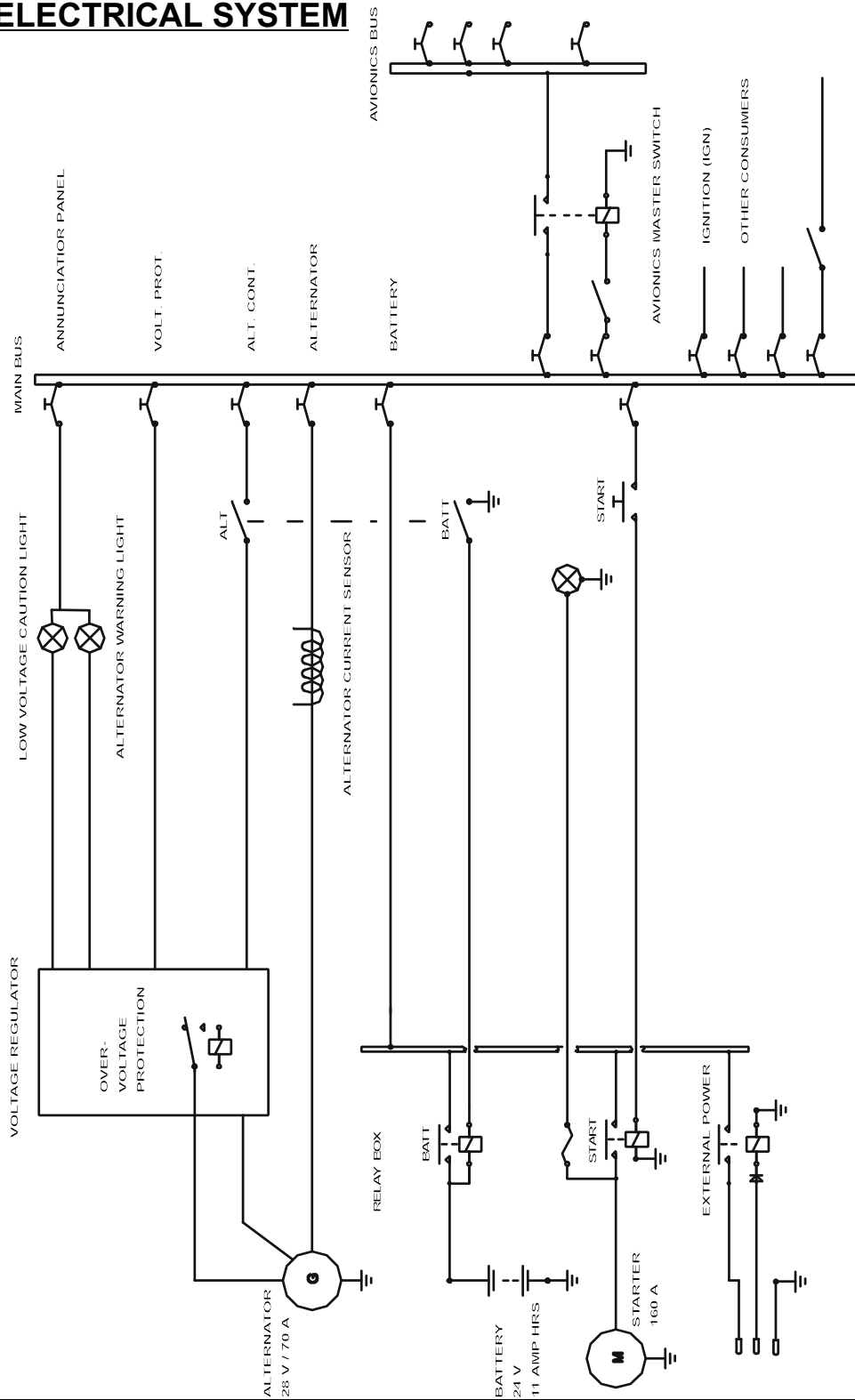

Simplified wiring diagram for serial numbers without Essential Bus

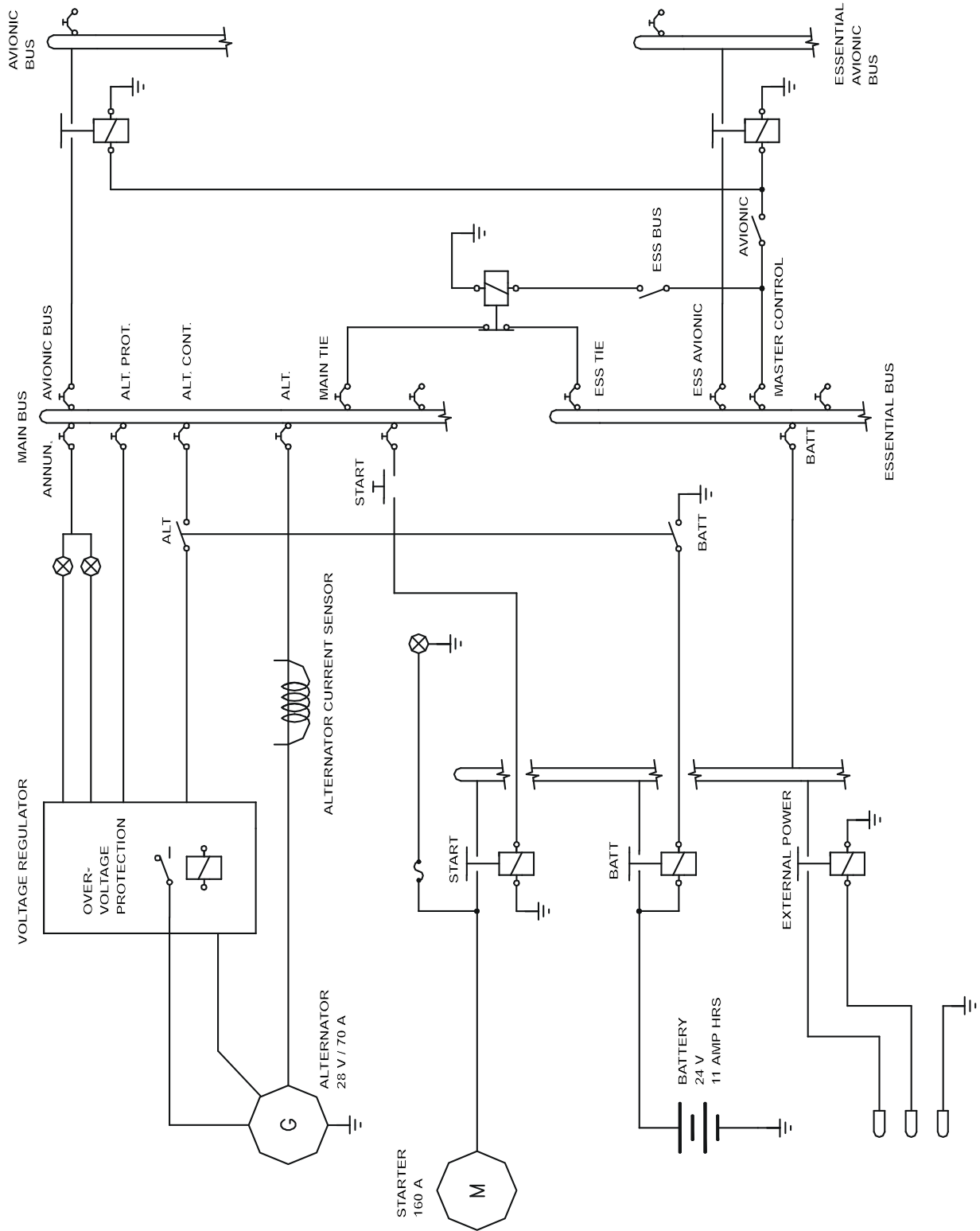

Simplified wiring diagram for serial numbers with Essential Bus

7.11.1 GENERAL

The DA 40 has 28 Volt DC system, which can be sub-divided into:

- Power generation
- Storage
- Distribution
- Consumers

Power Generation

The 70 Ampère alternator (generator) is mounted on the front of the engine. It is driven by a V-belt, and charges the battery. In the event of alternator failure, the battery provides the system with electrical energy. Given the provision of these two independent sources of electrical power, the complete failure of the electrical system is extremely unlikely.

Storage

Power is stored in a lead-acid battery which is mounted in the right-hand side of the engine compartment. It has a capacity of 10 Ampère-hour or more, depending on the battery type. The battery is connected to the airplane electrical system via the main (70 Ampère) circuit breaker.

In addition, a non-rechargeable dry battery or a lithium battery pack is installed in the IFR model as a further source of power for the attitude gyro (artificial horizon) and the flood light. When the emergency switch is set to ON, these two systems are supplied with power for 1 hour and 30 minutes, independent of all other electrical consumers.

Distribution

Electrical power is distributed via the main bus and, if installed, the essential bus.

Master Switch (ALT/BAT)

The Master switch is divided into a Master switch (ALT) on the left and a Master switch (BAT) on the right. Both switches together are known as the Master switch (ALT/BAT).

Consumers

The individual consumers (e.g. radio, electrical fuel pump, position lights, etc.) are connected to the main bus via automatic circuit breakers.

Designations and abbreviations used to identify the circuit breakers are explained in Section 1.5 - DEFINITIONS AND ABBREVIATIONS.

Ignition

The basic version of the DA 40 is equipped with the electric start boost system SlickSTART. This system improves the start characteristics by delivering more spark energy during the engine start sequence. After engine starting the ignition is controlled by the conventional retard breaker magneto system.

As an option, the LASAR electronic ignition control unit can be installed instead of the SlickSTART system. This unit measures manifold pressure and RPM and uses these parameters to optimize the ignition timing. This provides for smooth engine running and improved starting behavior. If the electronic ignition control is not in operation, the status light for the ignition illuminates and the conventional magneto ignition takes over the ignition control. Also, during operation of the engine on only one magneto, for example during the magneto check, the ignition is not controlled electronically and the status light for the ignition should illuminate. For engine restart in flight without the electronic ignition control being operative an engine speed of more than 500 RPM is necessary. The magneto ignition is independent of the electrical network, therefore providing safe engine operation even in the event of a power failure.

Voltmeter

The voltmeter displays the potential on the main bus. If the alternator is operating, the alternator voltage is shown, otherwise it is that provided by the battery.

Ammeter

The ammeter displays the current with which the alternator is being loaded.

Landing and Taxi Lights

Landing and taxi lights are built into the left wing, and are each operated by means of a switch (LANDING, TAXI) on the row of switches on the instrument panel.

Position and Strobe Lights

Combined position and strobe lights (anti collision lights) are installed on both wing tips. Each system is operated by a switch (POSITION, STROBE) on the row of switches on the instrument panel.

Flood Light

A two-dimensional light emitter is mounted above the instrument panel. It illuminates the instrument panel as well as all levers, switches, etc. With a rotary button (FLOOD) in the left-hand section of the instrument panel the flood light is switched on and its brightness is adjusted.

Instrument Lighting

With a rotary button (INSTRUMENT) in the left-hand section of the instrument panel the internal lighting of the instruments is switched on and its brightness is adjusted.

Pitot Heating

The Pitot probe, which provides measurement for the Pitot-static system, is electrically heated. The heating is activated with a switch (PITOT) on the row of switches on the instrument panel. The temperature is automatically kept constant by means of a thermal switch on the Pitot probe, and as an additional safety measure a thermal fuse is built in. If this thermal fuse is activated, the Pitot heating can no longer be switched on, and the Pitot heating caution will be displayed. In this case the system should be serviced.

NOTE

The Pitot heating caution will also be displayed whenever the Pitot heating system is switched OFF.

7.11.2 DAI ANNUNCIATOR PANEL **(WARNING, CAUTION AND STATUS LIGHTS)**

There are two variants of the annunciator panel ('DAI' and 'White Wire'). The 'DAI' variant, which is described below, can be identified by the lights in the shape of a square.

Testing the Annunciator Panel

In the process of the pre-flight check the lights of the annunciator panel must be checked by operating the test switch. This is to check that the lights have not failed. All lights must be serviceable.

Alternator Warning Light (ALT)

The alternator warning light illuminates on alternator failure. The only remaining source of electrical power is the battery. The color is red.

The procedure to be followed upon alternator warning is given in 3.7.2 - FAILURES IN THE ELECTRICAL SYSTEM.

Low Voltage Caution Light (VOLT)

This caution light illuminates when the on-board voltage drops below 24 Volts. It goes out again when the voltage exceeds 25 Volts. The color is amber.

The procedure to be followed upon low voltage caution is given in 4B.3 - FAILURES IN THE ELECTRICAL SYSTEM.

Fuel Pressure Warning Light (FUEL PR)

The fuel pressure warning light illuminates when the fuel pressure drops below 14 PSI. The color is red.

Low Fuel Caution Lights (L FUEL and R FUEL)

Each tank has its own caution light. It starts to flash when the fuel quantity becomes low, and illuminates permanently when the quantity of usable fuel in the respective tank drops below 3 US gal (± 1 US gal). The indication is calibrated for straight and level flight. The light may illuminate during turns which are flown with slip, or while taxiing in curves. The color is amber.

Oil Pressure Warning Light (OIL PR)

The oil pressure warning light illuminates when the oil pressure drops below 25 PSI. The color is red.

The procedure to be followed upon oil pressure warning is given in 3.2.3 - ENGINE PROBLEMS IN FLIGHT.

Door Warning Light (DOOR)

The door warning light illuminates when the front canopy and/or the rear door is not closed and locked. The color is red.

The procedure to be followed upon door warning is given in 3.7.4 - DOOR-WARNING LIGHT ON.

Status Light for the Ignition (IGN)

This light is only used when the electronic ignition control unit is installed.

The status light for the ignition illuminates when the electronic ignition control is not operating. In this case the conventional magneto ignition will be in use. The color is white.

The procedure to be followed upon illumination of the ignition status light is given in 4B.3 - FAILURES IN THE ELECTRICAL SYSTEM

Starter Warning Light (START)

The starter warning light illuminates when the starter is being operated or when the connection between the starter motor and the engine has not been broken. This occurs when the pinion of the starter motor remains engaged with the propeller flywheel. The color is red.

The procedure to be followed upon starter warning is given in 3.7.2 - FAILURES IN THE ELECTRICAL SYSTEM.

Pitot Heating Caution Light (PITOT)

The Pitot heating caution light is illuminated when the Pitot heating is not switched on, or when there is a failure of the Pitot heating system. The color is amber.

Prolonged operation of the Pitot heating on the ground can also cause the Pitot heating caution light to illuminate. In this case it indicates the activation of the thermal switch, which prevents overheating of the Pitot heating system on the ground. This is a normal function of the system. After a cooling period, the heating system will be switched on again automatically.

7.11.3 WHITE WIRE ANNUNCIATOR PANEL (WARNING, CAUTION AND STATUS LIGHTS)

There are two variants of the annunciator panel ('DAI' and 'White Wire'). The 'White Wire' variant, which is described below, can be identified by the flat front panel and the 'White Wire' logo on the display in the upper left corner.

Testing the Annunciator Panel

In the process of the pre-flight check, proper functioning of the annunciator panel must be verified. This functional check is automatically started after switching the battery master switch ON. All lights are flashed, and the aural alert is muted. By pressing the 'acknowledge' button, the lights are extinguished, and a momentary aural alert is sounded. This test verifies functionality of the microprocessor, the lights, and the aural signal.

The pilot may initiate additional system tests by holding the 'acknowledge' button for 2 seconds. All lights will begin flashing, and the aural alert will sound continuously.

Warning Messages

A warning is indicated by a continuous aural alert (sounded in the airplane's intercom system), flashing of the red WARNING light, and flashing of the red warning light associated with the affected system.

By pressing the 'acknowledge' button, which is now illuminated green, the aural alert will be terminated, and the WARNING light will be extinguished. The warning light associated with the affected system will change from flashing to solid illumination.

Caution Messages

A caution is indicated by a momentary aural alert (sounded in the airplane's intercom system), flashing of the amber CAUTION light, and flashing of the amber caution light associated with the affected system.

By pressing the 'acknowledge' button, which is now illuminated green, the CAUTION light will be extinguished. The caution light associated with the affected system will change from flashing to solid illumination.

The LOW FUEL caution message is displayed in a slightly different manner (extended functionality), which is described below.

Alternator Warning Message (ALTERNATOR)

The alternator warning message is displayed on alternator failure. The only remaining source of electrical power is the battery.

The procedure to be followed upon alternator warning is given in 3.7.2 - FAILURES IN THE ELECTRICAL SYSTEM.

Low Voltage Caution Message (LOW VOLTS)

The low voltage caution message is displayed when the on-board voltage drops below 24 Volts. It is terminated when the voltage exceeds 25 Volts again.

The procedure to be followed upon low voltage caution is given in 4B.3 - FAILURES IN THE ELECTRICAL SYSTEM.

Fuel Pressure Warning Message (FUEL PRESS)

The fuel pressure warning message is displayed when the fuel pressure drops below 14 PSI.

Low Fuel Caution Message (LOW FUEL)

As soon as the amount of usable fuel *in one tank* is less than 3 US gal (± 1 US gal), a caution message is displayed in the usual manner (momentary aural alert, flashing CAUTION light, flashing LOW FUEL caution light). Termination of the message is also done as usual ('acknowledge', CAUTION light is extinguished, LOW FUEL caution light changes to solid illumination).

As soon as the amount of usable fuel *in the second tank* is also less than 3 US gal (± 1 US gal), a caution message is displayed in a different manner. A *continuous* aural alert is sounded in the airplane's intercom system, the amber CAUTION light is flashed, and the amber LOW FUEL caution light is flashed.

By pressing the 'acknowledge' button, which is now illuminated green, the aural alert will be terminated, and the CAUTION light will be extinguished. The LOW FUEL caution light will continue to be flashed.

The indication is calibrated for straight and level flight. The caution message may be triggered during turns which are flown with slip, or while taxiing in curves.

Oil Pressure Warning Message (OIL PRESS)

The oil pressure warning message is displayed when the oil pressure drops below 25 PSI.

The procedure to be followed upon oil pressure warning is given in 3.2.3 - ENGINE PROBLEMS IN FLIGHT.

Door Warning Message (DOORS)

The door warning message is displayed when the front canopy and/or the rear door is not closed and locked.

The procedure to be followed upon door warning is given in 3.7.4 - DOOR-WARNING LIGHT ON.

Status Light for the Ignition (IGN)

This light is only used when the electronic ignition control unit is installed.

The status light for the ignition is illuminated when the electronic ignition control is not operating. In this case the conventional magneto ignition will be in use. The color is white.

The WARNING light, the CAUTION light, and the aural alert will *not* be activated.

The procedure to be followed upon illumination of the ignition status light is given in 4B.3 - FAILURES IN THE ELECTRICAL SYSTEM.

Starter Warning Message (START)

The starter warning message is displayed when the connection between the starter motor and the engine has not been broken. This occurs when the pinion of the starter motor remains engaged with the propeller flywheel.

Furthermore, the START warning light is illuminated continuously as long as the starter is being operated. In this case the WARNING light and the aural alert will not be activated.

The procedure to be followed upon starter warning is given in 3.7.2 - FAILURES IN THE ELECTRICAL SYSTEM.

Pitot Heating Caution Message (PITOT)

The Pitot heating caution message is displayed when the Pitot heating is not switched on, or when there is a failure of the Pitot heating system.

Prolonged operation of the Pitot heating on the ground can also cause the Pitot heating caution message to be displayed. In this case it indicates the activation of the thermal switch, which prevents overheating of the Pitot heating system on the ground. This is a normal function of the system. After a cooling period, the heating system will be switched on again automatically.

Trim Failure Warning Message (TRIM FAIL)

The White Wire annunciator panel is prepared for the installation of an autopilot in the DA 40. When the autopilot is installed and ready for operation, this warning message indicates a failure of the automatic trim system of the autopilot. For further details, refer to the Supplement to the AFM for the autopilot (if installed).

Unused Lights

The White Wire annunciator panel has two lights for possible future use. These lights are currently unused.

7.12 PITOT-STATIC SYSTEM

Total pressure is measured at the leading edge of a Pitot probe under the left wing. Static pressure is measured at two orifices at lower and rear edges of the same probe. To protect against dirt and condensation there are filters in the system, which are accessible from the wing root. The Pitot probe is electrically heated.

In addition, some serial numbers have an alternate static valve installed on the underside of the instrument panel. With this valve, the static pressure in the cabin can be used as static pressure source in the event of a failure of the Pitot-static system.

If an autopilot system is installed, additional static sources may be installed (OÄM 40-267).

7.13 STALL WARNING

If airspeed drops below approximately 10 to minimum 5 knots above the stalling speed, the stall warning horn, located in the instrument panel, will sound. The horn becomes progressively louder the closer one gets to stalling speed. Suction at an orifice on the left wing leading edge activates the horn via a hose. The orifice for the stall warning in the left wing is marked by a red ring.

7.14 AVIONICS

The radio and navigation equipment is located in the central part of the instrument panel. A transmit switch for the radio is mounted on the end of each control stick. There are connection facilities for up to 4 headsets between the front seats.

7.15 CO-MONITOR (IF INSTALLED)

The airplane may be equipped with a CO detector (OÄM 40-253).

7.15.1 SELF TEST SEQUENCE

When power is applied to the CO detector, a self-test routine begins. The test checks for functionality of the critical components such as the CO sensor, temperature sensor, and the integrity of the total CO detector system.

The remote alert light will flash twice. Then the remote light will remain OFF until there is another CO alert or until a failure of the unit occurs.

7.15.2 IN-FLIGHT CO ALARM

If the CO detector visual alert annunciator illuminates in flight, press the TEST/RESET button.

If the alert continues with the remote light staying ON, proceed with the emergency procedure 3.7.3 - SUSPICION OF CARBON MONOXIDE CONTAMINATION IN THE CABIN.

NOTE

The remote light will stay on until the CO level goes below 50 PPM.

7.15.3 UNIT FAILURE INDICATION

A failure of the CO sensor, temperature sensor, or the micro-controller will result in the following failure indications:

The remote light will flash at an approximately rate of one flash each four seconds until the failure is cleared or power is removed from the unit.

**Airplane
Description**



DA 40 AFM

I

Intentionally left blank.

I

Page 7 - 58

Rev. 9

31-Jan-2014

Doc. # 6.01.01-E

CHAPTER 8

AIRPLANE HANDLING, CARE AND MAINTENANCE

	Page
8.1 INTRODUCTION	8-2
8.2 AIRPLANE INSPECTION INTERVALS	8-2
8.3 AIRPLANE ALTERATIONS OR REPAIRS	8-3
8.4 GROUND HANDLING / ROAD TRANSPORT	8-3
8.4.1 GROUND HANDLING WITHOUT TOW BAR	8-3
8.4.2 GROUND HANDLING WITH TOW BAR	8-3
8.4.3 PARKING	8-5
8.4.4 MOORING	8-7
8.4.5 JACKING	8-7
8.4.6 ALIGNMENT	8-7
8.4.7 ROAD TRANSPORT	8-8
8.5 CLEANING AND CARE	8-9
8.5.1 PAINTED SURFACES	8-9
8.5.2 CANOPY AND REAR DOOR	8-10
8.5.3 PROPELLER	8-10
8.5.4 ENGINE	8-10
8.5.5 INTERIOR SURFACES	8-11
8.6 DE-ICING ON THE GROUND	8-12

8.1 INTRODUCTION

Chapter 8 contains the manufacturer's recommended procedures for proper ground handling and servicing of the airplane. The Airplane Maintenance Manual (Doc. No. 6.02.01) lists certain inspection and maintenance requirements which must be followed if the airplane is to retain a new plane performance and reliability.

8.2 AIRPLANE INSPECTION INTERVALS

For maintenance work on engine and propeller, the currently effective Operator's Manuals, Service Instructions, Service Letters and Service Bulletins of Lycoming and mt-Propeller must be followed. For airframe inspections, the currently effective checklists/manuals of the manufacturer must be followed.

CAUTION

Unscheduled maintenance checks are required after:

- Hard landings.
- Propeller strike.
- Engine fire.
- Lighting strike.
- Occurrence of other malfunctions and damage.

Unscheduled maintenance checks are described in the Airplane Maintenance Manual (Doc. No. 6.02.01; Section 05-50).

8.3 AIRPLANE ALTERATIONS OR REPAIRS

Alterations or repairs of the airplane may be carried out only according to the Airplane Maintenance Manual, Doc. No. 6.02.01, and only by authorized personnel.

8.4 GROUND HANDLING / ROAD TRANSPORT

8.4.1 GROUND HANDLING WITHOUT TOW BAR

During forward traversing the nose wheel will follow the movement of the airplane. Change in direction is achieved by pulling on the propeller near the spinner. To traverse in the rear direction, the tail section of the airplane should be pushed down until the nose wheel is clear of the ground. This method can also be used to turn the airplane around its main landing gear.

8.4.2 GROUND HANDLING WITH TOW BAR

For pushing or pulling the airplane on the ground, it is recommended to use the tow bar which is available from the manufacturer. The tow bar is bent apart and engaged in the appropriate holes in the nose wheel fairing as shown on the picture below. The arresting knob must be fully engaged.

WARNING

The tow bar must be removed before starting the engine.

CAUTION

The tow bar may only be used for moving the airplane on the ground by hand. After moving the airplane, the tow bar must be removed.

NOTE

When moving the airplane rearward, the tow bar must be held firmly to prevent abrupt sideward deflection of the nose wheel.



8.4.3 PARKING

For short term parking, the airplane must be positioned into the wind, the parking brake must be engaged and the wing flaps must be in the retracted position. For extended and unattended parking, as well as in unpredictable wind conditions, the airplane must be anchored to the ground or placed in a hangar. Parking in a hangar is recommended.

Control Surfaces Gust Lock

The manufacturer offers a control surfaces gust lock which can be used to block the primary controls. It is recommended that the control surfaces gust lock be used when parking outdoors, because otherwise the control surfaces can hit the stops in strong tail wind. This can lead to excessive wear or damage.

WARNING

The control surfaces gust lock must be removed before flight.

The control surfaces gust lock is installed as follows:

1. Move the rudder pedals fully rearward.
2. Engage the control surfaces gust lock with the pedals.
3. Engage the stick, wrap straps around stick once.
4. Attach the locks and tighten the straps.

For removal, reverse the sequence.



8.4.4 MOORING

The tail fin of the airplane has a hole which can be used to tie-down the airplane to the ground. Also on each wing near the wing tip, an eyelet with a metric M8 thread can be installed and used as tie-down points.

8.4.5 JACKING

The DA 40 can be jacked at the two jackpoints located on the lower side of the fuselage's LH and RH root ribs as well as at the tail fin.

8.4.6 ALIGNMENT

For alignment push down on the tail section at the fuselage/vertical tail junction until the nose wheel is clear of the ground. With the nose wheel free, the DA 40 can be turned around the main landing gear. After turning the airplane into the correct position, release the tail section until the nose wheel is back on the ground.

8.4.7 ROAD TRANSPORT

For transporting the airplane on the road it is recommended that an open trailer be used. All airplane components must be stored on a cushioned surface and secured to avoid any movement during transportation.

1. Fuselage:

The fuselage should stand on the main and nose landing gear. It must be ensured that the fuselage will not move in a forward, backward or upward direction. Furthermore, it must be ensured that the propeller has sufficient clearance so that it cannot be damaged due to fuselage movement during transportation.

2. Wings:

For transportation, both wings must be removed from the fuselage. To avoid any damage, the wings are stored in an upright position on the leading edge with the root rib area positioned on an upholstered profiled surface with a width of at least 400 mm (1.3 ft). The outside wing area (approximately 3 m (10 ft) from the root rib area) is placed on an upholstered profiled surface with a minimum width of 300 mm (1 ft).

The wings must be secured to avoid any sliding movement to the rear.

3. Horizontal Stabilizer:

The horizontal stabilizer is stored flat on the trailer and secured with straps, or in an upright position sitting on the leading edge on a profiled surface. All storing surfaces must be upholstered with felt or cellular rubber.

8.5 CLEANING AND CARE

CAUTION

The airplane must be kept clean. The bright surface prevents the structure from overheating.

CAUTION

Excessive dirt deteriorates the flight performance.

8.5.1 PAINTED SURFACES

The entire surface of the airplane is painted with a white weatherproof two component paint. Nevertheless, it is advantageous to protect the airplane against moisture and dampness. It is recommended to park the airplane in a hangar for prolonged storage. Moisture that has penetrated must be removed by storing the affected parts in a dry place and turning them over several times.

Dirt, insects, etc. can be removed with water alone and if necessary with a mild detergent. An automotive paint cleaner can be used for stubborn spots. For best results, clean the airplane after the day's flying is ended, so that the dirt will not become ingrained.

Oil stains, exhaust stains, etc. on the lower fuselage skin can be removed with a cold detergent. Before starting, ensure that the detergent does not affect the surface finish. Use commercial automotive preservatives without silicone additives to conserve the paint finish.

8.5.2 CANOPY AND REAR DOOR

The canopy and rear door should be cleaned with 'Plexiklar' or any other acrylic glass detergent if available; otherwise use lukewarm water. Final cleaning should be done with a clean piece of chamois-leather or soft cloth. Never rub or polish dry acrylic glass.

8.5.3 PROPELLER

Damage and malfunctions during operation must be inspected by authorized personnel.

Surface

The manufacturer uses PU paint or acrylic paint which is resistant to almost any solvent. The blades may be treated with commercial automotive cleaning agents or preservatives. The penetration of moisture into the wooden core must be avoided by all means. Should doubts arise, an appropriately rated inspector must be consulted.

8.5.4 ENGINE

Engine cleaning is part of the scheduled inspections.

CAUTION

Do not use acidic detergents (e.g. automotive wheel cleaners)
for cleaning the exhaust system.

8.5.5 INTERIOR SURFACES

The interior should be cleaned using a vacuum cleaner. All loose items (pens, bags etc.) should be removed or properly stored and secured.

All instruments can be cleaned using a soft dry cloth, plastic surfaces should be wiped clean using a damp cloth without any cleaning agents.

The leather interior should be treated with leather sealer within 3 months since new, and then at intervals of 3 to 6 months. Clean the leather interior with an appropriate mild leather cleaning agent and a soft cleaning brush for leather.

Note that the acrylic glass windows transmit the ultraviolet radiation from the sun.

8.6 DE-ICING ON THE GROUND

Approved De-Icing Fluids

Manufacturer	Product
Kilfrost	TKS 80
Aeroshell	Compound 07
Any source	AL-5 (DTD 406B)

De-Icing Procedure

1. Remove any snow from the airplane using a soft brush.
2. Spray de-icing fluid onto ice-covered surfaces using a suitable spray bottle.
3. Use a soft piece of cloth to wipe the airplane dry.

CHAPTER 9 SUPPLEMENTS

	Page
9.1 INTRODUCTION	9-2
9.2 LIST OF SUPPLEMENTS	9-3

9.1 INTRODUCTION

Chapter 9 contains information concerning additional (optional) equipment of the DA 40.

Unless otherwise stated, the procedures given in the Supplements must be applied in addition to the procedures given in the main part of the Airplane Flight Manual.

All approved supplements are listed in the List of Supplements in this Chapter.

The Airplane Flight Manual contains exactly those Supplements which correspond to the installed equipment according to the Equipment Inventory of Section 6.5.

9.2 LIST OF SUPPLEMENTS

Airplane S/N:		Registration:		Date:	
Sup. No.	Title	Rev. No.	Date	applicable	
				YES	NO
A1	COMM/NAV, KX 125 Bendix/King	1	20-Apr-2001	<input type="checkbox"/>	<input type="checkbox"/>
A2	Intercom System, Model PM 1000 II PS Engineering, Inc.	2	15-Mar-2005	<input type="checkbox"/>	<input type="checkbox"/>
A3	Transponder, KT 76A Bendix/King	1	20-Apr-2001	<input type="checkbox"/>	<input type="checkbox"/>
A4	GPS, KLN 89B Bendix/King	1	20-Apr-2001	<input type="checkbox"/>	<input type="checkbox"/>
A5	Course Deviation Indicator, KI 208 Bendix/King	1	20-Apr-2001	<input type="checkbox"/>	<input type="checkbox"/>
A6	GPS, KLN 94 (VFR Operation) Bendix/King	2	09-Sep-2001	<input type="checkbox"/>	<input type="checkbox"/>
A7	Audio Amplifier / Intercom / Marker Beacon Receiver, KMA 28 Bendix/King	1	20-Apr-2001	<input type="checkbox"/>	<input type="checkbox"/>
A8	VHF Communication/Navigation Transceivers, KX 155A and KX 165A Bendix/King	2	03-Oct-2001	<input type="checkbox"/>	<input type="checkbox"/>

Airplane S/N:		Registration:		Date:	
Sup. No.	Title	Rev. No.	Date	applicable	
				YES	NO
A9	Automatic Direction Finder, KR 87 Bendix/King	2	17-Feb-2003	<input type="checkbox"/>	<input type="checkbox"/>
A10	Distance Measuring Equipment, KN 62A Bendix/King	2	17-Feb-2003	<input type="checkbox"/>	<input type="checkbox"/>
A11	Compass System, KCS 55A Bendix/King	4	15-Mar-2005	<input type="checkbox"/>	<input type="checkbox"/>
A12	Transponder, KT 76C Bendix/King	2	15-Mar-2005	<input type="checkbox"/>	<input type="checkbox"/>
A13	Autopilot System, KAP 140 Bendix/King	2	15-Mar-2005	<input type="checkbox"/>	<input type="checkbox"/>
A14	GPS, KLN 94 (IFR Operation) Bendix/King	3	15-Mar-2005	<input type="checkbox"/>	<input type="checkbox"/>
A15	GPS Annunciation Control Unit, MD 41 Mid-Continent	2	15-Mar-2005	<input type="checkbox"/>	<input type="checkbox"/>
A16	Multifunction Display / GPS KMD 150, Bendix/King	0	20-Sep-2001	<input type="checkbox"/>	<input type="checkbox"/>
A17	COM / NAV / GPS GNS 430, Garmin	3	22-Jun-2005	<input type="checkbox"/>	<input type="checkbox"/>
A18	Audio Panel, GMA 340, Garmin	2	22-Jun-2005	<input type="checkbox"/>	<input type="checkbox"/>
A19	Transponder, GTX 327, Garmin	1	15-Mar-2005	<input type="checkbox"/>	<input type="checkbox"/>

Airplane S/N:

Registration:

Date:

Sup. No.	Title	Rev. No.	Date	applicable	
				YES	NO
A20	Course Deviation Indicator, GI 106A, Garmin	1	15-Mar-2005	<input type="checkbox"/>	<input type="checkbox"/>
A21	COM / NAV / GPS, GNS 530, Garmin	1	15-Mar-2002	<input type="checkbox"/>	<input type="checkbox"/>
A22	Strike Finder, SF 2000, Insight	0	10-Oct-2001	<input type="checkbox"/>	<input type="checkbox"/>
A23	GPS Annunciation Unit, MD 41-1488/1484, MID Continent	1	20-Dec-2002	<input type="checkbox"/>	<input type="checkbox"/>
A24	Stormscope, WX-500, Goodrich	2	28-Feb-2003	<input type="checkbox"/>	<input type="checkbox"/>
A25	Audio Panel, GMA 340, Garmin, VFR	2	15-Mar-2005	<input type="checkbox"/>	<input type="checkbox"/>
A26	COM / NAV / GPS, GNS 430, Garmin, VFR	0	02-Aug-2002	<input type="checkbox"/>	<input type="checkbox"/>
A27	Ground Com #2 Switch	0	05-Apr-2002	<input type="checkbox"/>	<input type="checkbox"/>
A29	Transponder, GTX 330, Garmin	0	25-Jun-2003	<input type="checkbox"/>	<input type="checkbox"/>
E1	Digital Chronometer, LC-2 AstroTech	1	20-Apr-2001	<input type="checkbox"/>	<input type="checkbox"/>
E2	Attitude Indicator, AIM 1100-28L(0F) BF Goodrich	2	15-Mar-2005	<input type="checkbox"/>	<input type="checkbox"/>

Airplane S/N:		Registration:		Date:	
Sup. No.	Title	Rev. No.	Date	applicable	
				YES	NO
E3	Attitude Indicator, AIM 1100-28LK(0F) DIA BF Goodrich	2	15-Mar-2005	<input type="checkbox"/>	<input type="checkbox"/>
E4	Digital Chronometer, Model 803, Davtron	1	15-Mar-2005	<input type="checkbox"/>	<input type="checkbox"/>
E7	Ventilation Inlet Baffle	1	27-Apr-2005	<input type="checkbox"/>	<input type="checkbox"/>
O1	Use of the DA 40 as Tow-Plane	1	28-Nov-2001	<input type="checkbox"/>	<input type="checkbox"/>
O2	Operation of the DA 40 with Winter Kit	0	26-Nov-2001	<input type="checkbox"/>	<input type="checkbox"/>
S1	Emergency Locator Transmitter, Model E-01, ACK	2	15-Mar-2005	<input type="checkbox"/>	<input type="checkbox"/>
S2	Emergency Locator Transmitter, JE2-NG, Jolliet	0	01-Jun-2001	<input type="checkbox"/>	<input type="checkbox"/>
S4	ELT Artex ME 406 'ACE'	1	10-Apr-2007	<input type="checkbox"/>	<input type="checkbox"/>